

A photograph of a modern outdoor terrace overlooking the ocean under a blue sky with clouds. The terrace features a light-colored stone or concrete floor and a dark, possibly metal, railing. The ocean is a deep blue, and the sky is a clear, bright blue with scattered white clouds. The overall scene is bright and airy, suggesting a high-end outdoor living space.

OUTDOOR
GERVASONI
1882

OUTDOOR
GERVASONI
1882

Outdoor Collections by:

Chiara Andreatti

Federica Biasi

Gabriele & Oscar Buratti

Paola Navone

Nendo

David Lopez Quincoces

Elena Sanguaneko

Gervasoni Outdoor Designers

IT. Progettisti e designer dai background differenti creano per Gervasoni collezioni immaginate per vivere il tempo all'aria aperta. Un'incessante ricerca - volta a proporre le migliori soluzioni per un comfort contemporaneo - porta l'azienda a sperimentare modi sempre nuovi per dare forma al proprio universo outdoor. La scelta dei materiali, le innovative lavorazioni e la cura dei particolari diventano gli elementi caratterizzanti di ogni progetto.

EN.

Architects and designers from different backgrounds collaborate with Gervasoni to create collections designed to spend time in the open air. An incessant research aimed at proposing the most suitable solutions for a contemporary comfort, leads the company to experiment newer ways to give shape to its outdoor universe. The selection of materials, the innovative workmanship and the care for details become the main features of each project.

FR.

Des concepteurs et des designers venus d'horizons différents collaborent avec Gervasoni pour créer des collections qui explorent le monde du mobilier d'extérieur. Une recherche incessante pour proposer les solutions les plus adaptées au confort contemporain a conduit l'entreprise à expérimenter de nouvelles manières de donner forme à son propre univers outdoor. Le choix des matériaux, le souci du détail et des processus innovants deviennent un outil d'expression pour chaque projet.

DE.

Planer und Designer mit unterschiedlichem Hintergrund arbeiten mit Gervasoni zusammen, um breit gefächerte Kollektionen mit Outdoor-Möbeln zu erschaffen. Eine unaufhörliche Recherche, die darauf abzielt, die am besten geeigneten Lösungen für einen zeitgemäßen Komfort zu liefern, bringt das Unternehmen dazu, mit immer neuen Methoden zu experimentieren, um dem eigenen Outdoor-Universum Form zu verleihen. Die Auswahl der Materialien, die innovativen Verarbeitungen und die Liebe zum Detail werden zum expressiven Instrument eines jeden Projektes.

Outdoor Collections

IT. La collezione Gervasoni Outdoor è il risultato di un'attenta selezione di materiali naturali e tecnici lavorati con sapienti manualità e innovative tecnologie. I prodotti Gervasoni Outdoor si adattano ai diversi stili abitativi, arredano con assoluta facilità ed eleganza terrazzi, giardini o piscine, dagli ambienti più urbani e contemporanei ai più sofisticati o immersi nella natura. La varietà di finiture, di materiali e di tessuti consente di personalizzare il proprio spazio outdoor senza vincoli di stile.

EN.

The Gervasoni Outdoor collection is the result of a careful selection of natural and technical materials, all skilfully crafted by expert hands and innovative technologies. The Gervasoni Outdoor products adapt to different styles of living, furnishing terraces, gardens or pools with absolute ease and elegance, from the most modern and contemporary spaces to more sophisticated or natural contexts. The range of finishes, materials and fabrics allows the personalisation of outdoor spaces without any restrictions on style.

FR.

La collection Gervasoni Outdoor est le fruit d'une sélection minutieuse de matériaux naturels et techniques travaillés avec une grande habileté et technologies innovantes. Les produits Gervasoni Outdoor s'adaptent avec élégance et extrême facilité aux différentes manières d'habiter, que ce soit dans l'aménagement de terrasses, de jardins ou de piscines, pour créer des ambiances urbaines et contemporaines, sophistiquées ou naturelles. La variété des finitions, des matériaux et des tissus permet de personnaliser son propre espace extérieur sans contraintes de style.

DE.

Die Kollektion Gervasoni Outdoor ist das Ergebnis einer sorgfältigen Auswahl natürlicher und technischer Materialien, die mit großer handwerklicher Kunstfertigkeit und innovativer Technologie verarbeitet werden. Die Gervasoni Outdoor - Produkte passen sich den verschiedenen Arten, im Freien zu leben, perfekt an und statten Terrassen, Gärten oder Schwimmbereiche auf elegante und unkomplizierte Weise aus, von urbanen und zeitgemäßen Räumen bis hin zu raffinierten und in die Natur eingebetteten Räumen. Dank der Vielzahl von Ausführungen, Materialien und Stoffen sind dem persönlichen Stil im eigenen Outdoor-Bereich keine Grenzen gesetzt.





Index

Hashi Collection	009
Jeko Collection	029
Kasane Collection	057
Flair Collection	067
Brise Collection	087
Inout Collection	103
Guna Collection	155
Inout 700 Collection	169
Ghost Out Collection	185
Panda Collection	203
Straw Collection	219
Heiko	282
Eco Rugs Collection	302
Tables	232
Chairs	261
Complements	275
Abacus	309



Hashi Collection

Design by
Federica Biasi

Hashi Collection

IT. Ispirazioni orientali ed esotiche definiscono Hashi, collezione disegnata da Federica Biasi e composta da divano componibile e sedia a dondolo. Letteralmente “bacchette” in giapponese, Hashi dà vita a prodotti caratterizzati da incontri di stili, sapori e culture differenti.



EN.

Oriental and exotic inspirations define Hashi, the collection designed by Federica Biasi, including a modular sofa and a rocking chair. Literally “chopsticks” in Japanese, Hashi presents products characterised by the encounter with different styles, flavours and cultures.

FR.

Des inspirations orientales et exotiques définissent Hashi, une collection dessinée par Federica Biasi qui se compose d'un canapé modulaire et d'un rocking-chair. Hashi, qui signifie « baguettes » en japonais, donne vie à des produits caractérisés par des rencontres entre des styles, des saveurs et des cultures différents.

DE.

Orientalische und exotische Inspirationen definieren Hashi, eine von Federica Biasi designte Kollektion aus modularem Sofa und Schaukelstuhl. Wörtlich aus dem Japanischen übersetzt, bedeutet Hashi „Stäbchen“ und lässt Produkte entstehen, die sich durch Begegnungen aus unterschiedlichen Stilen, Geschmäckern und Kulturen auszeichnen.



Hashi 05

Brise 53



→ Hashi configuration 07:
Divano/ Sofa in Sahara 02-D.
Loose cushions: 2 C. Hashi S
in Odessa 01-C, Sahara 06-D;
2 C. Hashi XS in Sahara 06-D,
Odessa 01-C.
→ Rug Eco 02 Natural:
Tappeto/ Carpet.

Guna 12

Guna 01

Brise 53



Hashi Configuration 07

Brise 43

Brise 54

Rug Eco 02 Natural



Hashi 05

Hashi Configuration 05

Brise 53



← Hashi configuration 05:
Divano/ Sofa in Aspen 02-C.
Loose cushions: 2 C. Hashi S in
Odessa 01-C, Sahara 04-D; 1 C.
Hashi XS in Odessa 01-C.
← Hashi 05: Poltrona/ Armchair
in Odessa 01-C.



Hashi Configuration 04

Guna 11



Hashi Configuration 02

Guna 12

Brise 53

← Hashi configuration 04:
Divano/ Sofa in Sahara 03-D.
Loose cushions: 1 C. Hashi S in
Cannes 04-C.
← Hashi configuration 02:
Divano/ Sofa in Cannes 04-C.
Loose cushions: 1 C. Hashi S in
Sahara 03-D.

→ Hashi configuration 01:
Divano/ Sofa in Aspen 04-C.
→ Hashi configuration 04:
Divano/ Sofa in Odessa 01-C.
Loose cushion: 1 C. Hashi S
in Odessa 04-C.

→ Hashi 09: Dondolo/ Rocking chair.
Loose cushion: 1 C. Hashi XS
in Odessa 01-C.
→ Rug Guna 03 Blue: Tappeto/ Carpet.
→ Rug Guna 02 Blue: Tappeto/ Carpet.
→ Rug Guna 01 Blue: Tappeto/ Carpet.



Hashi 09



*Hashi
Configuration 04*

Brise 43

Brise 46

Rug Guna 02 Blue

Rug Guna 03 Bue

Brise 44

Hashi Configuration 01



Brise 43

Hashi 09

Rug Guna 01 Blue

Rug Guna 02 Blue

Rug Guna 03 Blue

Brise 46





Brise 54

Brise 43

*Hashi
Configuration 06*

Rug Eco 02 Green

← Hashi configuration 06:
Divano/ Sofa in Oslo 05-C.
Loose cushions: 2 C.
Hashi S in Oslo 09-C.
← Rug Eco 02 Green:
Tappeto/ Carpet.



023



Hashi Collection

Materials, Colors, Drawings →

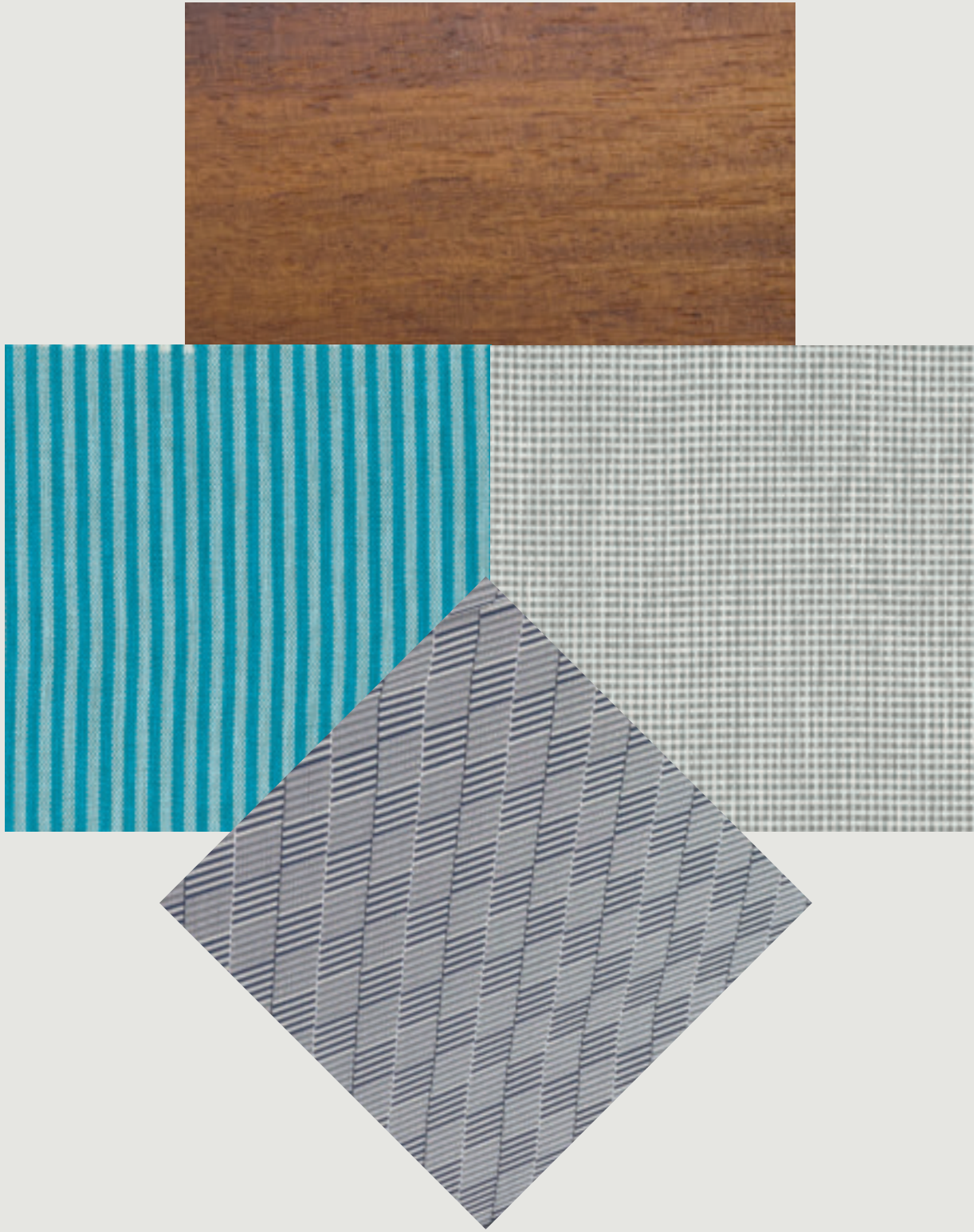

Iroko + Jaquard Accardi Fabric



Il legno Iroko è una specie particolarmente dura proveniente dalle foreste dei paesi dell'Africa equatoriale. Essendo un legno resinoso è per natura protetto dall'acqua e dall'umidità. Ha notevoli qualità meccaniche, come la particolare resistenza alla flessione. Il tessuto Jaquard Accardi è un tessuto ad alto contenuto tecnico lavorato da sapienti artigiani tessili. Con anima in poliestere e rivestimento in PVC, è impermeabile, resistente ai raggi UV, durevole, leggero e di facile pulizia. È inoltre antialga, antibatterico, antimuffa, traspirante e atossico.

L'iroko est une espèce particulièrement dure provenant des forêts d'Afrique équatoriale. En tant que résineux, il est naturellement protégé de l'eau et de l'humidité. Il possède de remarquables propriétés mécaniques, comme sa résistance particulière à la flexion. Le tissu Jacquard Accardi est un tissu à haut contenu technique, produit par des tisserands chevronnés. Avec une âme en polyester et un revêtement en PVC, il est imperméable, résistant aux rayons UV, durable, léger et facile à nettoyer. Il est en outre anti-algues, antibactérien, anti-moisissures, transpirant et atoxique.

Iroko wood is a particularly hard species from the forests of tropical Africa. Being a resinous wood, it is naturally protected against water and moisture. It features impressive mechanical qualities, such as resistance to bending. The Accardi Jacquard fabric is a high technical content fabric crafted by skilled textile artisans. With a polyester soul and a PVC covering, it is waterproof, resistant to UV rays, durable, lightweight and easy to clean. It is also anti-algae, anti-bacterial, anti-mould and non-toxic breathable.

Iroko ist ein besonders hartes Holz aus den Wäldern Äquatorialafrikas. Da es sich um ein harzreiches Holz handelt, ist es von Natur aus wasser- und feuchtigkeitsfest. Es besitzt außergewöhnliche mechanische Eigenschaften, darunter die besondere Festigkeit. Der Jacquard-Stoff Accardi ist ein höchst funktionaler Stoff, der von erfahrenen Textilhandwerkern hergestellt wird. Mit einem Kern aus Polyester und einer Beschichtung aus PVC ist er undurchlässig, beständig gegen UV-Strahlen, dauerhaft, leicht und einfach zu reinigen. Außerdem ist er algenhemmend, antibakteriell, schimmelhemmend, atmungsaktiv und ungiftig.

Slate Stainless Steel



Caratterizzato da stabilità e forza, resistenza alla ruggine e a una maggiore resistenza all'ossidazione e alla corrosione, l'acciaio inox trattato per esterni è ampiamente utilizzato negli arredi outdoor. Il trattamento finale migliora la stabilità agli agenti atmosferici e all'inquinamento.

Caractérisé par stabilité et force, résistance à la rouille et une résistance accrue à l'oxydation et à la corrosion, l'acier inoxydable traité pour l'extérieur est largement utilisé pour le mobilier d'extérieur. Le traitement final améliore la stabilité aux agents atmosphériques et à la pollution.

Characterised by stability and strength, resistance to rust and a greater resistance to oxidation and corrosion, the stainless steel treated for outdoors is widely used in outdoor furnishings. The final treatment improves the stability to weather agents and to pollution.

Geprägt durch Stabilität und Kraft, Rostbeständigkeit und hohe Beständigkeit gegenüber Oxidation und Korrosion, wird der für Außenbereiche behandelte Edelstahl häufig in Outdoor-Umgebungen eingesetzt. Die Endbehandlung verbessert die Witterungs- und Schmutzbeständigkeit.

Upholstery



L'imbottitura dei cuscini di seduta e schienale è realizzata in poliuretano espanso per renderla più compatta e resistente. La perfetta impermeabilizzazione delle imbottiture è garantita dal rivestimento con fodere in poliestere, trattate con specifici prodotti idrorepellenti e idrorepellenti, e dalle cuciture termosaldate. Tutti i cuscini e le parti imbottite in collezione sono sfoderabili.

Le garnissage des assises et des dossiers est réalisé en polyuréthane expansé afin de les rendre plus compacts et résistants. Il est parfaitement imperméabilisé grâce à des housses en polyester aux propriétés hydrofuges et hydrophobes et grâce aux coutures thermosoudées. Tous les coussins et les parties rembourrées de la collection sont déhoussables.

The padding of the seat and back cushions is made of polyurethane foam to improve their compactness and resilience. The perfect water-repellence is guaranteed by the polyester cushion covers, treated with specific waterproof and water-repellent products, and the heat welded seams. All the cushions and upholstered elements of the collection have removable covers.

Die Polsterung der Sitze und Rückenlehnen wird aus Polyurethanschaum hergestellt, wodurch sie besonders kompakt und widerstandsfähig sind. Die perfekte Abdichtung der Polsterung wird durch die Polyester Überzüge garantiert, die mit speziellen wasserabweisenden Produkten behandelt und mit Thermobandierung versehen sind. Sämtliche Kissen und Polster Elemente der Kollektion sind abziehbar.

Hashi 05
p. 011, 014

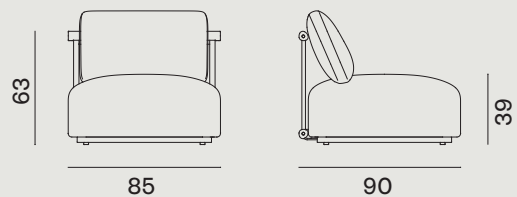

Hashi 06

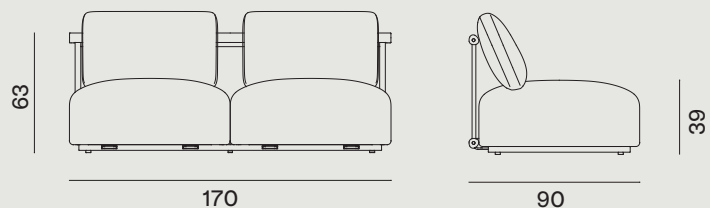

Hashi 06 AN

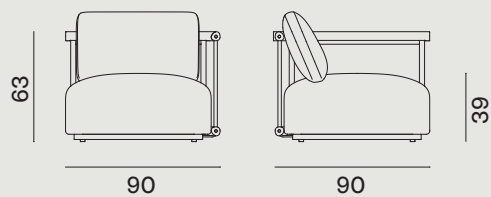

Hashi 08

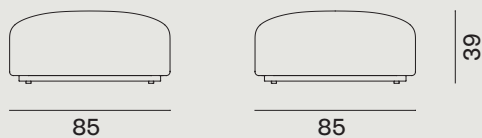

Hashi 09
p. 018-019, 020, 021

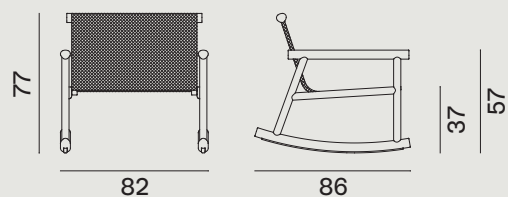

C. Hashi XS

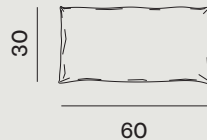

C. Hashi S

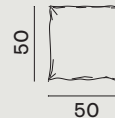

Hashi Configuration 01
p. 018-019

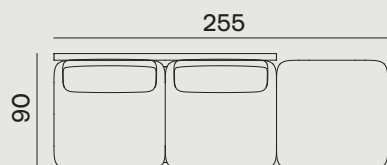

Hashi Configuration 02
p. 016-017

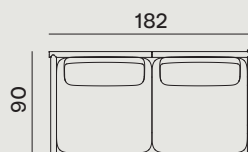

Hashi Configuration 03

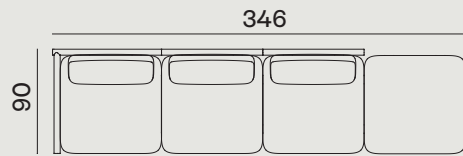

Hashi Configuration 04
p. 016-017, 018-019

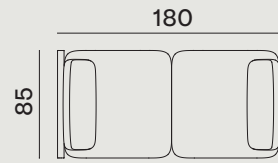

Hashi Configuration 05
p. 014

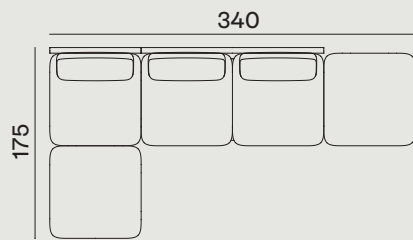

Hashi Configuration 06
p. 022, 023

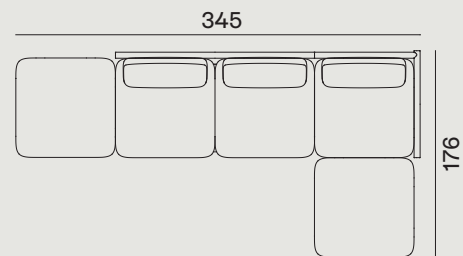

Hashi Configuration 07
p. 012-013

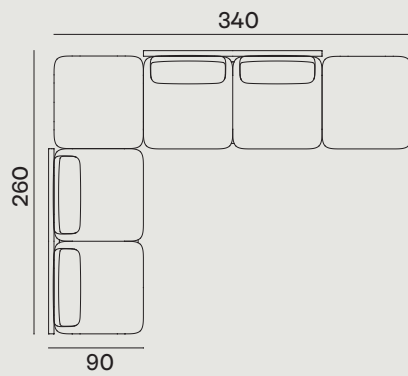

Hashi Configuration 08

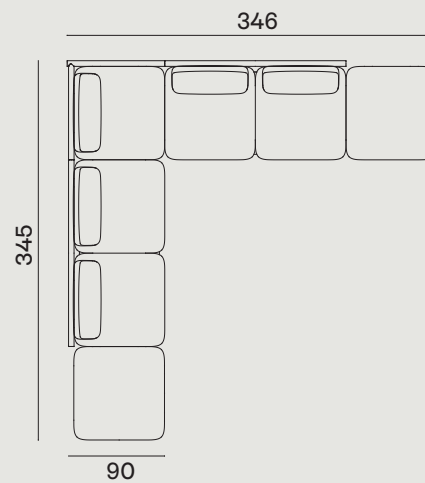



Jeko Collection

Design by
Paola Navone

Jeko Collection

IT. Il fascino del mood esotico ispira la collezione Jeko. Le sedute e i tavoli, in versione dining e lounge e il lettino hanno la struttura realizzata in ECOTEak, materiale proveniente dal riutilizzo di travi ed elementi recuperati dalla demolizione - autorizzata dalle autorità locali - delle tradizionali case in legno dell'isola di Giava, Indonesia. Gli elementi recuperati sono tagliati a misura, riparati con legno riciclato, assemblati e levigati per evidenziare le venature originali e infine lucidati a mano con panni di canapa e trucioli. La sua linea sinuosa è completata dai cuscini soffici e avvolgenti.



EN.

The allure of an exotic mood is the inspiration for the Jeko collection. The frames of dining and lounge seats, tables and day-bed are in ECOTEak, a material obtained from recycled teak beams and elements recovered from the demolition of traditional wooden homes on the island of Java, Indonesia, authorised by local authorities. The recovered elements are cut to size, repaired with recycled wood, assembled and sanded to highlight the original grain, and finally hand-polished with hemp cloths and shavings. Its curvy profile is completed by soft, cozy cushions.

FR.

Le charme de l'exotisme inspire la collection Jeko. Les tables de repas, les guéridons, les sièges et le lit de repos Jeko possèdent une structure en ECOTEak provenant de poutres et d'éléments en teck issus de la démolition - autorisée par les autorités locales - des maisons traditionnelles en bois de l'île indonésienne de Java. Les éléments récupérés sont taillés sur mesure, réparés avec du bois recyclé, assemblés et poncés pour faire ressortir leurs veines naturelles. L'étape finale prévoit un cirage à la main à l'aide de tissus en chanvre et de copeaux. Des coussins moelleux et accueillants viennent compléter ses lignes sinueuses.

DE.

Die Kollektion Jeko ist von einem exotischen Flair inspiriert. Die Eß- und Couchtische sowie die Sitzelemente und die Liege der Kollektion Jeko besitzen ein Gestell aus ECOTEak, einem Material, das durch die Wiederverwendung von Balken und Elementen aus Teak dank des kontrollierten und genehmigten Abrisses der traditionellen Holzhäuser auf der indonesischen Insel Java gewonnen wird. Die Elemente werden maßgeschneidert, mit recyceltem Holz ausgebeesert, zusammengesetzt und geschliffen, um die ursprüngliche Maserung hervorzuheben, und schließlich von Hand mit Hanftüchern und Holzspänen poliert. Die geschwungene Silhouette wird durch weiche Kissen komplettiert.





Jeko 24

Jeko 31

↑ Jeko 31: Tavolo quadrato.
Base in ECOTEak, piano in
marmo bianco Carrara./ Square
table. ECOTEak legs, white
Carrara marble top.
↑ Jeko 24: Sedia/ Chair.
Optional cushion in Sahara
01-D (stitching Navy).
↑ Ghost out 23: Sedia/ Chair
in Sahara 01-D (stitching Navy).

→ Jeko 81: Lettino/
Day-bed in Dublin 07-C
(stitching Blu Scuro).
→ Rug Eco 02 White:
Tappeto/ Carpet.





Jeko 40

Jeko 81

Jeko 41

Rug Eco 02 White



Jeko 81

Jeko 40



→ Jeko 24: Sedia/ Chair.
Optional cushion in Dublin
01-C (stitching Navy).
→ Jeko 35: Tavolo quadrato.
Base in ECOTEak, piano in
marmo bianco Carrara./Square
table. ECOTEak legs, white
Carrara marble top.



→ Jeko 26: Poltrona/
Armchair. Cuscino/ Cushion
in Sahara 04-D.
→ Rug Guna 03 Blue:
Tappeto/ Carpet.
→ Rug Guna 01 Blue:
Tappeto/ Carpet.



Jeko 14

Jeko 26

Guna 12

Jeko 41

Jeko 40

Rug Guna 01 Blue

Rug Guna 03 Blue



Jeko 04

Jeko 11

Inout 47, 49



← Jeko 04: Divano/ sofa.
Seduta/seat in Capri 06-C.
Cuscini/ cushions: 3 80x80 in
Capri 07-C; 3 60x60 in Capri
03-C, Capri 01-C; 2 Ø20x90
in Capri 06-C.

Jeko 05

Inout 48

Inout 49

← Jeko 05: Poltrona/ armchair.
Seduta/seat in Capri 06-C.
Cuscini/ cushions: 1 60x60 in
Capri 01-C; 1 50x50 in Capri
03-C.

← Jeko 05: Poltrona/ armchair.
Seduta/seat in Capri 06-C.
Cuscini/ cushions: 1 60x60 in
Capri 03-C; 1 50x50 in Capri
03-C.



Jeko 04

Jeko 11



Inout 48

Jeko 05



Jeko 07

Inout 41, 42, 43



← Jeko 07: Divano a baldacchino/ canopy sofa.
Seduta/seat in Oslo 05-C.
Cuscini/ cushions: 3 80x80 in Oslo 03-C; 4 60x60 in Oslo 05-C, Oslo 07-C; 4 Ø20x90 in Oslo 07-C.



Jeko 07





Inout 44

Jeko 04

Jeko 11

Jeko 01

← Jeko 04: Divano/ sofa.
Seduta/seat in Aspen 04-C.
Cuscini/ cushions: 3 80x80 in
Berlin 06-C; 3 60x60 in Berlin
05-C, 2 Ø20x90 in Aspen
04-C (stitching Grigio Scuro).

←↓ Jeko 01: Poltrona/ armchair.
Seduta/seat in Aspen 02-C
(stitching Grigio Scuro).
Cuscini/ cushions: 1 80x80 in
Berlin 06-C; 1 60x60 in Berlin
05-C, 2 Ø20x90 in Aspen 02-C
(stitching Grigio Scuro).



→ Jeko 33: Tavolo rettangolare.
Gambe in ECOTEak, piano
in marmo bianco Carrara./
Rectangular table.
Legs in ECOTEak, white
Carrara marble top.





Random 96

Inout 42

Jeko 33

Inout 824





Jeko 33

Inout 824

Materials, Colors, Drawings →



ECOTEak

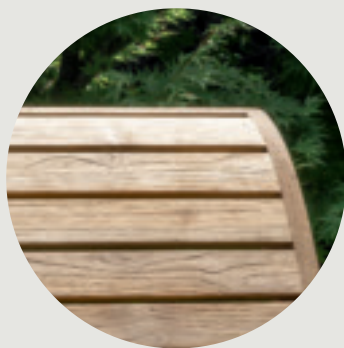

L'ECOTEak utilizzato per la collezione proviene dal riutilizzo di travi ed elementi in teak recuperati dalla demolizione delle tradizionali case in legno dell'isola di Giava, Indonesia. La finitura finale prevede la lucidatura a mano con panni di canapa e trucioli.

L'ECOTEak utilisé dans cette collection provient de poutres et d'éléments en teck récupérés lors de la démolition des maisons traditionnelles en bois de l'île indonésienne de Java. L'étape finale prévoit un cirage à la main à l'aide de tissus en chanvre et de copeaux.

The ECOTEak used in the collection is obtained from old teak beams and elements recovered from the demolition of traditional wooden homes on the Island of Java, in Indonesia. The final finish is obtained by hand polishing with hemp cloths and shavings.

Das ECO Teak, das für die Kollektion eingesetzt wird, geht auf wiederverwendete Balken und Elemente aus Teakholz zurück, die aus den abgerissenen traditionellen Holzhäusern der indonesischen Insel Java gewonnen werden. Das abschließende Finish basiert auf einer von Hand ausgeführten Politur mit Hanftüchern und Spänen.

White Carrara Marble

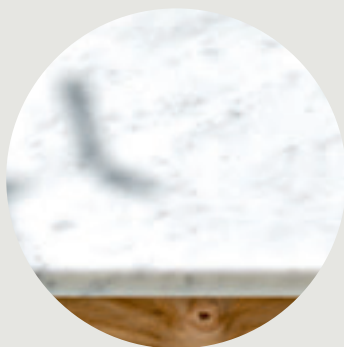

Alle qualità estetiche, il marmo abbina caratteristiche strutturali, fisiche e morfologiche che lo rendono naturalmente compatto, resistente all'usura e idoneo al contatto con gli alimenti. Il marmo utilizzato in collezione è trattato con impregnante protettivo trasparente opaco.

Le marbre allie à ses qualités esthétiques des propriétés structurelles, physiques et morphologiques qui le rendent naturellement solide, résistant à l'usure et adapté au contact avec les aliments. Le marbre utilisé dans cette collection est protégé à l'aide d'un imprégnant transparent opaque.

The aesthetic qualities of marble are combined with structural, physical and morphological characteristics making it naturally compact, resistant to wear and suitable for contact with food. The marble used in the collection is treated with a clear matt protective impregnating agent.

Neben seinen ästhetischen Qualitäten verbindet der Marmor strukturelle, physische und morphologische Eigenschaften, dank derer er von Natur aus kompakt, widerstandsfähig und für den Kontakt mit Lebensmitteln geeignet ist. Der für die Kollektion verwendete Marmor wird mit einer matt-transparenten Schutzschicht imprägniert.

Upholstery



L'imbottitura dei cuscini di seduta e schienale è realizzata in poliuretano espanso per renderla più compatta e resistente. La perfetta impermeabilizzazione delle imbottiture è garantita dal rivestimento con fodere in poliestere, trattate con specifici prodotti idrorepellenti e idrorepellenti, e dalle cuciture termosaldate. Tutti i cuscini e le parti imbottite in collezione sono sfoderabili.

Le garnissage des assises et des dossiers est réalisé en polyuréthane expansé afin de les rendre plus compacts et résistants. Il est parfaitement imperméabilisé grâce à des housses en polyester aux propriétés hydrofuges et hydrophobes et grâce aux coutures thermosoudées. Tous les coussins et les parties rembourrées de la collection sont déhoussables.

The padding of the seat and back cushions is made of polyurethane foam to improve their compactness and resilience. The perfect water-repellence is guaranteed by the polyester cushion covers, treated with specific waterproof and water-repellent products, and the heat welded seams. All the cushions and upholstered elements of the collection have removable covers.

Die Polsterung der Sitze und Rückenlehnen wird aus Polyurethanschaum hergestellt, wodurch sie besonders kompakt und widerstandsfähig sind. Die perfekte Abdichtung der Polsterung wird durch die Polyester Überzüge garantiert, die mit speziellen wasserabweisenden Produkten behandelt und mit Thermobandierung versehen sind. Sämtliche Kissen und Polsterelemente der Kollektion sind abziehbar.

Jeko 01
p. 046-047

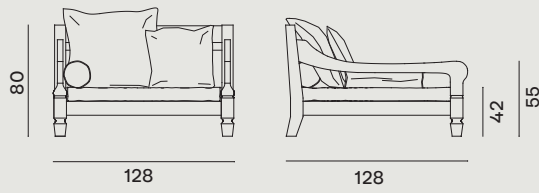

Jeko 04
p. 038-039, 040, 046-047



Jeko 05
p. 038-039, 041

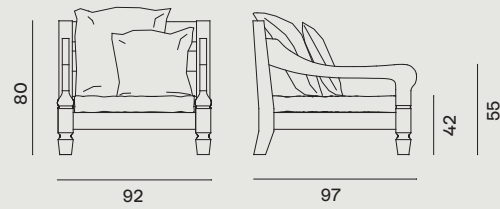

Jeko 07
p. 042-043, 044

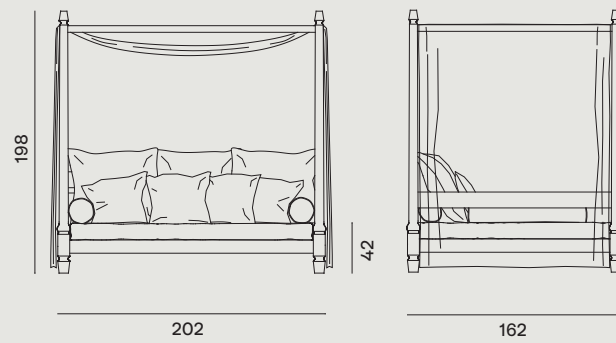

Jeko 11
p. 038-039, 040, 046

Tech. Spec. → p. 290

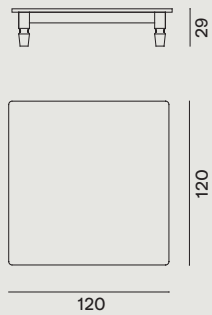

Jeko 14
p. 037

Tech. Spec. → p. 290

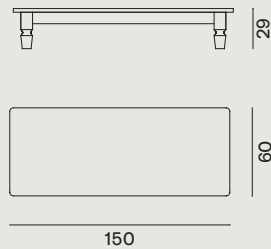

Jeko 24
p. 031, 032, 035

Tech. Spec. → p. 268

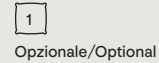
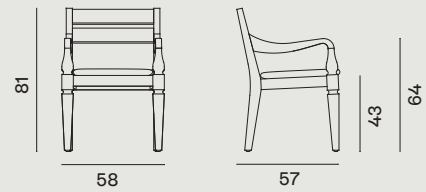

Jeko 26
p. 028, 037

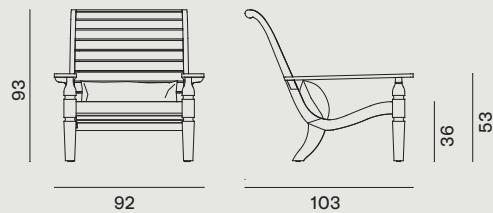

Jeko 31
p. 032

Tech. Spec. → p. 252

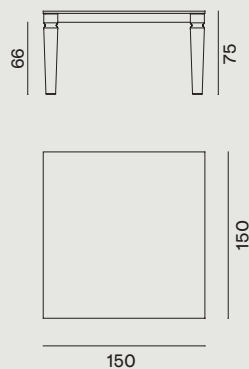

Jeko 33
p. 048-049, 051

Tech. Spec. → p. 252

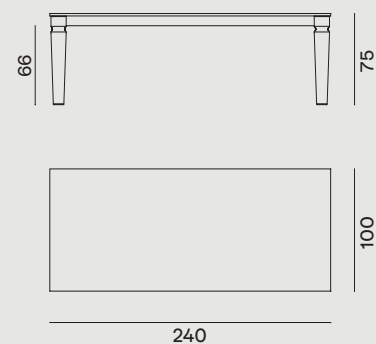

Jeko 34

Tech. Spec. → p. 252

Jeko 35

p. 031, 035

Tech. Spec. → p. 252

Jeko 40

p. 033, 034, 036, 191

Tech. Spec. → p. 291

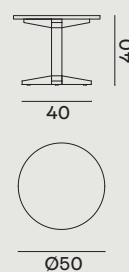
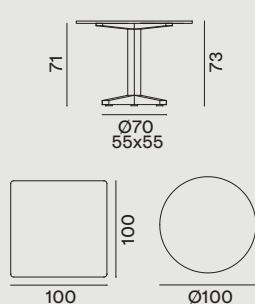
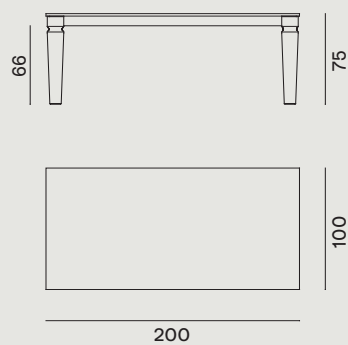

Jeko 41
p. 191

Tech. Spec. → p. 291

Jeko 46
p. 036, 191

Tech. Spec. → p. 291

Jeko 81
p. 033, 034

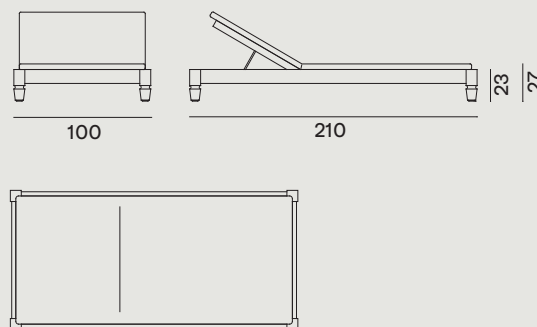
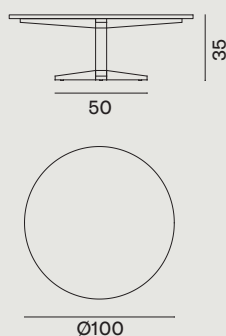
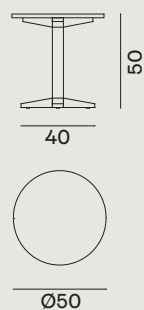

C. Jeko XS

C. Jeko PI

C. Jeko GR

C. Jeko PR

C. Jeko RU

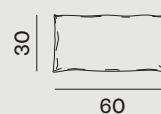
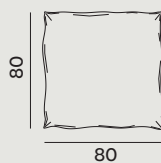
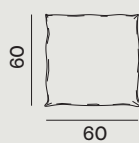
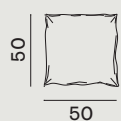



Kasane Collection

Design by
Nendo

Kasane Collection

IT. Letteralmente “sovrapporsi”, Kasane è la nuova collezione disegnata dallo studio giapponese Nendo. Grazie ad un gioco di incastri e sovrapposizioni di diversi elementi, ogni prodotto diventa una scultura. Ispirata dal modo in cui le tazze, impilandole una ad una, diventano gradualmente più alte, la collezione di pouf e tavoli è caratterizzata dall'espressione ritmica dei bordi impilati e dalla texture materica dell'argilla che definisce l'animo del prodotto.



EN.

Literally “overlapping”, Kasane is the latest collection designed by the Japanese studio, Nendo. Thanks to a play on the weaving and overlapping of different elements, each product becomes a sculpture. Inspired by the way in which the cups, stacked one on top of the other, become gradually taller, the collection of poufs and tables is characterised by the rhythmic expression of the piled edges and by the material texture of the clay which defines the soul of the product.

FR.

Kasane, qui signifie littéralement « superposer », est la nouvelle collection conçue par le studio japonais Nendo. Grâce à un jeu d'emboîtement et de superposition de différents éléments, chaque pièce devient une sculpture. Inspirée par la façon dont les tasses, qui s'empilent les unes sur les autres, prennent progressivement de la hauteur, la collection de poufs et de tables se caractérise par l'expression rythmique des bords empilés et par la texture matérielle de l'argile qui définit l'âme du produit.

DE.

Kasane, die neue Kollektion des japanischen Designbüros Nendo, bedeutet wörtlich „sich überlagern“. Durch das Zusammenspiel und die Überlagerung der verschiedenen Elemente wird jedes Produkt zu einer Skulptur. Die Kollektion, die Poufs und Tische umfasst, ist von der Art und Weise inspiriert, wie Tassen durch Übereinanderstapeln nach und nach höher werden. Die Kollektion zeichnet sich durch den rhythmischen Ausdruck der gestapelten Kanten und die materielle Textur des Tons aus, der die Seele des Produkts prägt.



Brise 23

Kasane 36

Brise 24

↑ Kasane 36: Tavolo tondo.
Base e piano in finitura
Terracotta./ Round table.
Central base and top in
Terracotta finish.



Kasane 33



Ghost Out 23

← Kasane 33: Tavolo ovale.
Base e piano in finitura
Terracotta./ Oval table. Legs
and top in Terracotta finish.
← Ghost Out 23: Sedia/ chair in
Aspen 04-C.

→ Kasane 36: Tavolo tondo.
Base e piano in finitura Sabbia./
Round table. Central base and
top in Sabbia finish.





Kasane 36

Brise 24



Polymer and clay

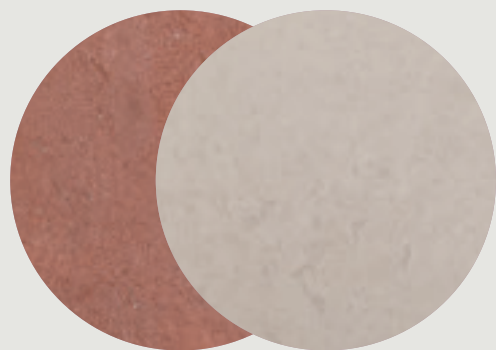

La basi dei tavoli e il pouf sono realizzati in polimero espanso, mentre i piani sono in MDF. Tutti gli articoli della collezione sono rivestiti con un sottile strato di argilla nei colori Terracotta o Sabbia. Grazie alla texture finale gli articoli esprimono matericità e una piacevole sensazione tattile.

Bases and pouf structures are made of polymer foam, while the table top is MDF. The products are covered with thin layer of clay in Terracotta or Sabbia colours. Thanks to the final texture, the articles express material nature and a pleasant tactile sensation.

Le piètements de la table et le pouf sont réalisés en polymère expansé, le plateau de la table est en MDF. Tous les produits sont revêtus d'une fine couche d'argile dans les couleurs Terracotta ou Sabbia. Grâce à la texture finale, les éléments expriment la matérialité et donnent une agréable sensation tactile.

Der Tischunterbau und der Pouf sind aus expandiertem Polymer, die Tischplatte ist aus MDF. Für beide Modelle gibt es eine dünne Ton-Deckschicht in den Farben Terracotta oder Sabbia. Dank der abschließenden Textur zeichnen sich die Artikel durch Materialität und eine angenehme Haptik aus.

Kasane 19

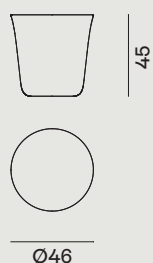

Kasane 33

p. 056, 060-061, 074-075

Tech. Spec. → p. 256

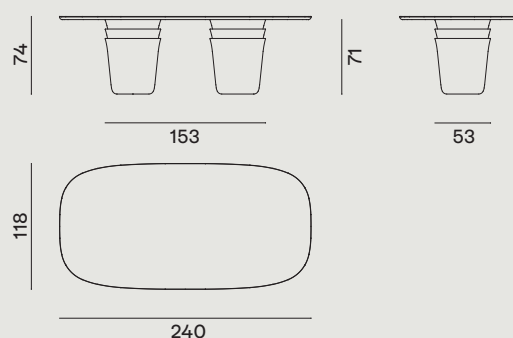

Tech. Spec. → p. 256

Kasane 35

Tech. Spec. → p. 256

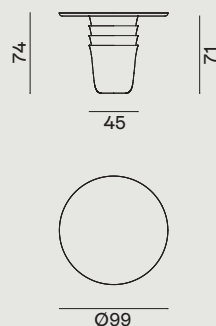

Kasane 36

p. 059, 062-063

Tech. Spec. → p. 256

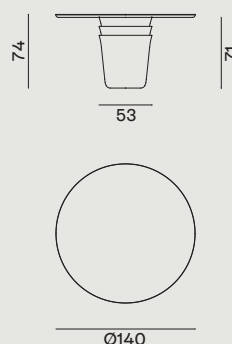



Flair Collection

Design by
Oscar & Gabriele Buratti

Flair Collection

IT. Flair, di Gabriele e Oscar Buratti, è un sistema modulare di sedute e schienali componibili in innumerevoli forme e dimensioni. Informale, morbido ed allo stesso tempo elegante, Flair è caratterizzato da uno schienale ribaltabile rivestito in tessuto trapuntato che definisce e movimentata lo skyline.



EN.

Flair, by Gabriele and Oscar Buratti, is a modular system of sectional seating and backrests in countless forms and dimensions. Informal, soft and at the same time elegant, Flair is characterized by a backrest covered with a quilted fabric that can be flipped-down defining and mixing up the skyline.

FR.

Flair, de Gabriele et Oscar Buratti, est un système modulaire d'assises et de dossiers permettant de composer d'innombrables formes et dimensions. À la fois informel, moelleux et élégant, Flair se distingue par un dossier rabattable recouvert d'un tissu matelassé qui définit et anime la ligne du meuble.

DE.

Flair von Gabriele und Oscar Buratti ist ein modulares System aus Sitzflächen und Rückenlehnen, die sich in unzähligen Formen und Größen zusammenstellen lassen. Informell, weich und gleichzeitig mit Eleganz, zeichnet sich Flair durch eine klappbare, mit einem Steppstoff bezogene Rückenlehne aus, die die Skyline definiert und bewegt.



Flair Configuration 04



Flair 01

Brise 56

Brise 54

Flair Configuration 04

Brise 43



→ Flair configuration 04:
Divano/ Sofa in Dublin 01-C.
Loose cushions: 3 C. Flair PI in
Dublin 02-C; 2 C. Flair XS in
Dublin 05-C.
→ Flair 01: Pouf/ Ottoman
in Dublin 02-C.



→ Flair configuration 02:
Divano/ Sofa in Odessa 01-C,
Odessa 02-C.
Loose cushions: 3 C. Flair PI
in Oslo 01-C, 2 C. Flair S
in Odessa 01-C, 1 C. Flair XS
in Odessa 01-C.



Flair configuration 02

Brise 56



Flair Configuration 01

Guna 11

Guna 11



Kasane 33

Guna 12

Guna 02

← Flair configuration 01:
Divano/ Sofa in Lisboa 02-C.
Loose cushions: 2 C. Flair PI in
Sahara 06-D; 1 C. Flair XS in
Sahara 06-D.
← Guna 02 Blue: Day-bed in
Odessa 01-C.



Guna 11

Rug Guna 03 Blue

Flair 01



- ← Flair configuration 03:
Divano/ Sofa in Aspen
03-C, Berlin 04-C.
Loose cushions: 2 C.
Flair PI in Dublin 02-C.
- ← Flair 01: Pouf/ Ottoman
in Dublin 02-C.
- ← Rug Guna 03 Blue:
Tappeto/ Carpet.
- ← Rug Guna 01 Blue:
Tappeto/ Carpet.

Inout 41

Rug Guna 01 Blue

Flair Configuration 03





Guna 12

Guna 11



Flair Configuration 01

Brise 44

Rug Guna 01 Blue



Brise 46



Brise 43

←↑ Flair configuration 01:
Divano/ Sofa in Sahara 08-D.
Loose cushions: 1 C. Flair PI in
Sahara 08-D; 2 C. Flair XS in
Madrid 05-C.
← Rug Guna 01 Blue: Tappeto/
Carpet.

Materials, Colors, Drawings →

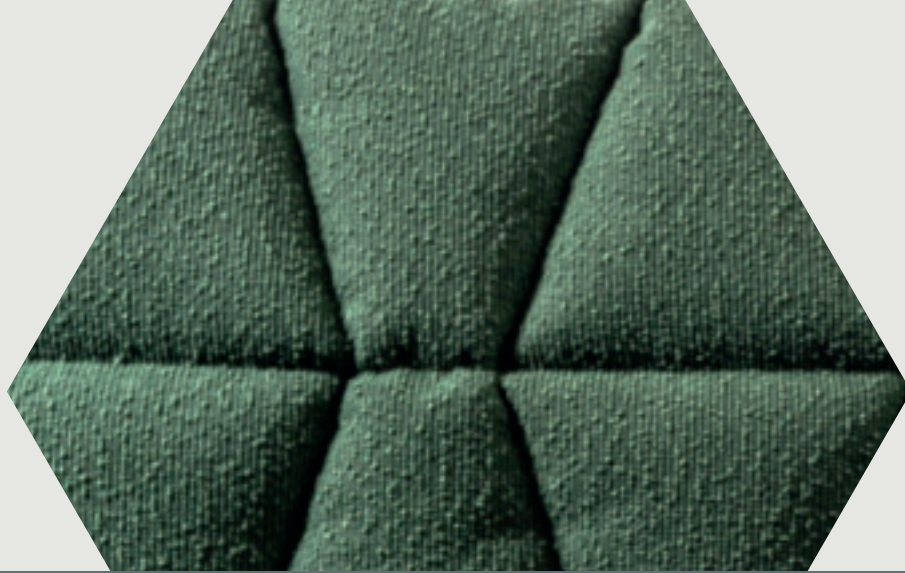

Slate Steel



La struttura dei divani Flair è in acciaio trattato per esterni e cinghie elastiche. Caratterizzato da stabilità e forza, l'acciaio trattato per esterni è ampiamente utilizzato negli arredi outdoor. Il trattamento finale migliora la stabilità agli agenti atmosferici e all'inquinamento.

La structure des canapés Flair est en acier traité pour l'extérieur et sangles élastiques. Caractérisé par stabilité et force, l'acier traité pour l'extérieur est largement utilisé pour le mobilier d'extérieur. Le traitement final améliore la stabilité aux agents atmosphériques, à la rouille et à la pollution.

Flair sofa frame is in steel treated for outdoors and elastic bands. Characterised by stability and strength, the steel treated for outdoors is widely used in outdoor furnishings. The final treatment improves the stability to weather agents and to pollution.

Das Gestell der Flair-Sofas ist aus für den Außenbereich behandeltem Stahl, mit elastischen Riemen. Geprägt durch Stabilität und Kraft, wird der für Außenbereiche behandelte Stahl häufig in Outdoor-Umgebungen eingesetzt. Die Endbehandlung verbessert die Witterungs-, Rost- und Schmutzbeständigkeit.

Upholstery



L'imbottitura dei cuscini di seduta e schienale è realizzata in poliuretano espanso per renderla più compatta e resistente. La perfetta impermeabilizzazione delle imbottiture è garantita dal rivestimento con fodere in poliestere, trattate con specifici prodotti idrofughi e idrorepellenti, e dalle cuciture termosaldate. Tutti i cuscini e le parti imbottite in collezione sono sfoderabili.

Le garnissage des assises et des dossiers est réalisé en polyuréthane expansé afin de les rendre plus compacts et résistants. Il est parfaitement imperméabilisé grâce à des housses en polyester aux propriétés hydrofuges et hydrophobes et grâce aux coutures thermosoudées. Tous les coussins et les parties rembourrées de la collection sont déhoussables.

The padding of the seat and back cushions is made of polyurethane foam to improve their compactness and resilience. The perfect water-repellence is guaranteed by the polyester cushion covers, treated with specific waterproof and water-repellent products, and the heat welded seams. All the cushions and upholstered elements of the collection have removable covers.

Die Polsterung der Sitze und Rückenlehnen wird aus Polyurethanschaum hergestellt, wodurch sie besonders kompakt und widerstandsfähig sind. Die perfekte Abdichtung der Polsterung wird durch die Polyester Überzüge garantiert, die mit speziellen wasserabweisenden Produkten behandelt und mit Thermobandierung versehen sind. Sämtliche Kissen und Polster Elemente der Kollektion sind abziehbar.

Flair O1
p. 069, 070-071, 076-077

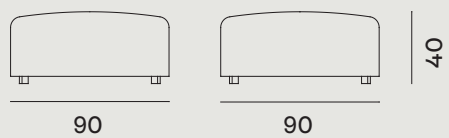

Flair O2

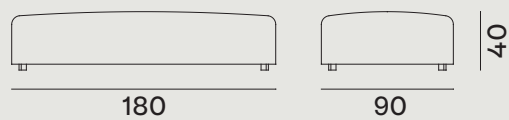

Flair O3

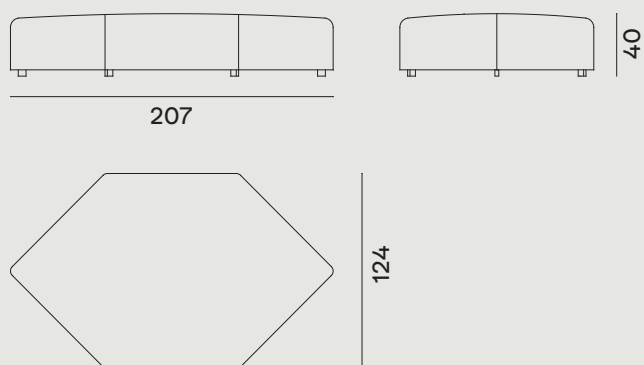

Flair 11

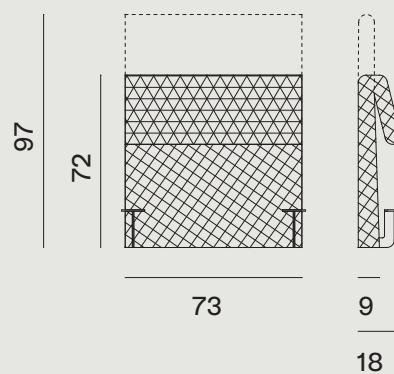

Flair Configuration 01
p. 074-075, 080, 081

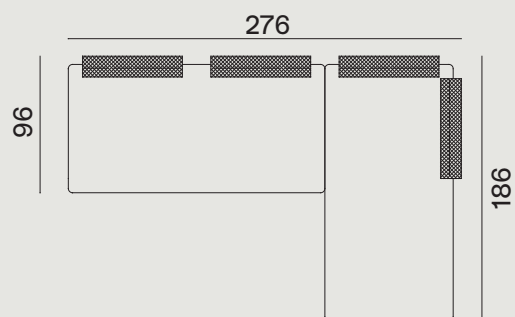

Flair Configuration 02
p. 073

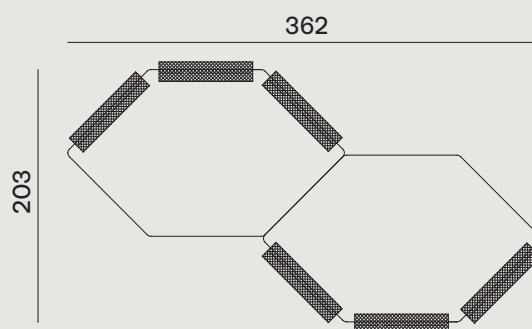

Flair Configuration 03
p. 076-077, 079

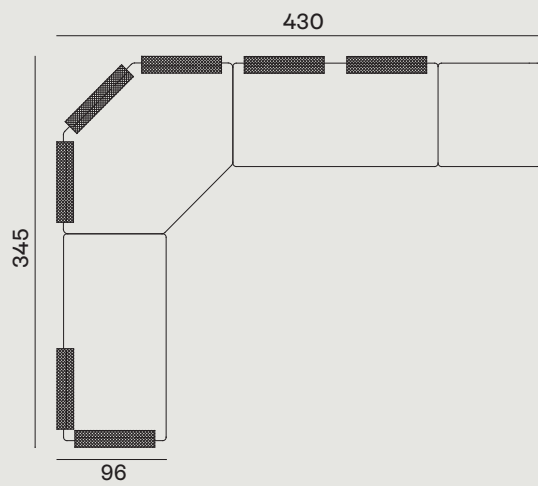

Flair Configuration 04
p. 069, 070-071

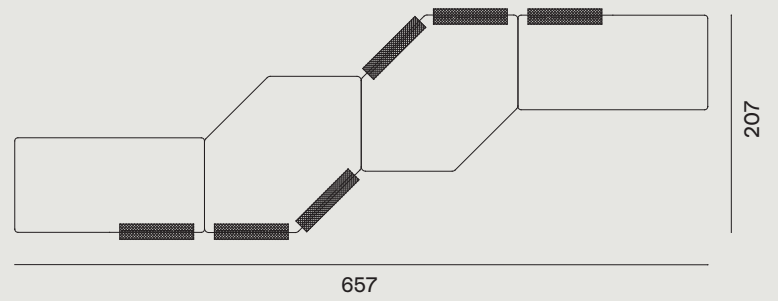

Flair Configuration 05

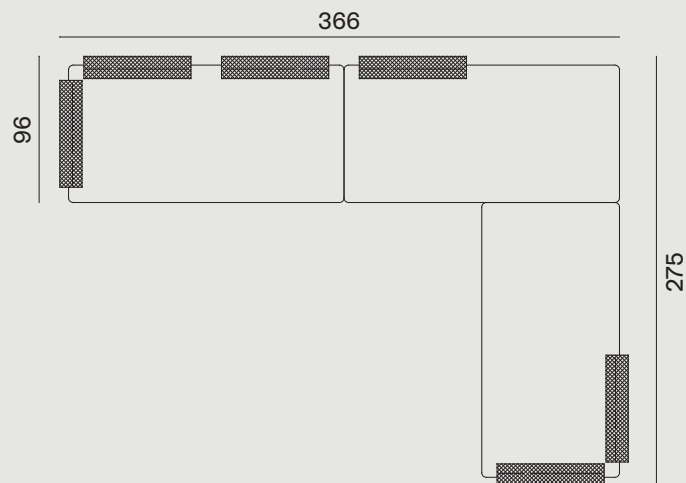

Flair Configuration 06

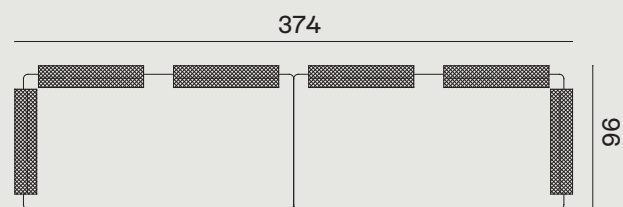

C.Flair XS

C.Flair S

C.Flair PI

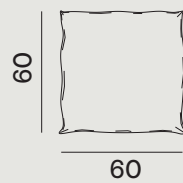
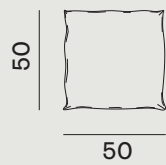
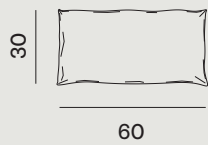



Brise Collection

Design by
Federica Biasi

Brise Collection

IT. La convivialità outdoor è la chiave della collezione Brise di Federica Biasi. Composta da sedute dining, tavoli e tavolini, Brise, letteralmente brezza, è una collezione vivace, elegante e frizzante al tempo stesso: rievoca l'Art Nouveau, lo stile floreale, liberty, definito da linee ornamentali e decorative che si ispirano alla natura per armonizzarsi con essa.



EN.

The outdoor conviviality is the key of the Brise collection by Federica Biasi. Composed of dining chairs, tables and side tables, Brise, literally breeze, is a lively collection, elegant and bubbly at the same time, calling to mind Art Nouveau, floral, liberty style, defined by ornamental and decorative lines that are inspired by nature to harmonise with it.

FR.

La convivialité en extérieur est un facteur déterminant pour la collection Brise de Federica Biasi. Sous ce nom qui signifie "vent léger" nous rassemblons une collection de chaises, tables et guéridons à la fois dynamique, élégante et pétillante : elle évoque l'Art Nouveau, le style floral, le liberty, défini par des lignes ornementales et décoratives qui s'inspirent à la nature pour s'harmoniser avec elle.

DE.

Geselligkeit im Freien ist grundlegend für die Brise-Kollektion von Federica Biasi. Brise, wie der leichte Windhauch, ist eine lebendige, elegante und gleichzeitig spritzige Kollektion aus Stühlen, Eß- und Beistelltischen: sie erinnert an Art Nouveau, den floralen Liberty- oder Jugendstil, geprägt durch ornamentale und dekorative Linien, die von der Natur inspiriert sind, um sich auf sie abzustimmen.





Brise 23



Brise 24



Brise 33

Ghost Out 23



← Brise 33: Tavolo rettangolare.
 Gambe in acciaio Pearl.
 Piano in cemento bianco./
 Rectangular table. Pearl steel
 legs. White concrete top.
 ← Ghost Out 23: Sedia/
 Chair in Aspen 03-C.
 ← Rug Guna 02 Natural:
 Tappeto/ Carpet.

↓ Brise 38: Tavolo quadrato.
 Base in acciaio Slate. Piano
 in cemento grigio./ Square
 table. Slate steel base.
 Grey concrete top.
 ↓ Ghost out 23: Sedia/ Chair
 in Dublin 05-C (stitching Navy).



Brise 38

Ghost Out 23







↑→ Brise 33: Tavolo rettangolare.
Gambe in acciaio Oxido. Piano
in lamiera forata Oxido. /
Rectangular table. Oxido steel
legs. Oxido perforated plate.



Brise 33

Inout 823

Inout 824



GRFC Concrete

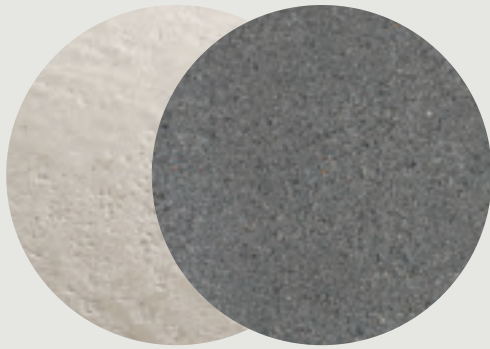

Prodotti realizzati con una miscela di cemento e fibra di vetro. Il prodotto finale si contraddistingue per una resistenza unica e una maggior durabilità nel tempo. I tavoli dining hanno il piano in cemento color bianco o grigio con decoro.

Products made from mixture of concrete and glass fiber. The final product stands out for its unique strength and for a greater durability over time. Dining tables have a white or grey concrete top with geometric decoration.

Les produits sont réalisés avec un mélange de béton et de fibre de verre. Le produit final se distingue par sa résistance unique et une plus grande durabilité dans le temps. Les tables ont un plateau en ciment blanc ou gris avec un décor géométrique.

Die Produkte bestehen aus einer Mischung von Zement und Glasfaser. Das Material zeichnet sich durch seine einzigartige Festigkeit sowie eine längere Lebensdauer aus. Die Esstische weisen eine Platte aus weißem oder grauem Zement mit geometrischem Dekor auf.

Millgres

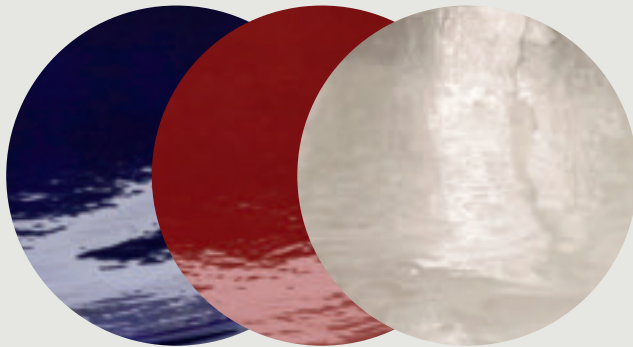

La resistenza agli agenti atmosferici e all'umidità rende il Millgres un materiale perfetto per il mondo outdoor. Inoltre, la facilità di manutenzione per le qualità antimacchia e di lavaggio con detergenti comuni, lo rendono idoneo anche al contatto con gli alimenti.

The resistance to weather agents and to humidity makes Millgres a perfect material for the outdoor world. Furthermore, the easy maintenance thanks to its stain-proof qualities and ability to be washed with common detergents make it also suitable to be used for foods.

Grâce à sa résistance aux agents atmosphériques et à l'humidité, le Millgres est un matériau parfait pour la vie à l'extérieur. Grâce à sa facilité d'entretien, à ses qualités antitaches et de nettoyage avec un détergent ordinaire, il est adapté au contact avec les aliments.

Die Witterungs- und Feuchtigkeitsbeständigkeit macht Millgres zu einem perfekten Material für die Outdoor-Welt. Außerdem machen es die einfache Instandhaltung dank seiner fleckenabweisenden Eigenschaften und die einfache Reinigung mit herkömmlichen Putzmitteln auch für den Kontakt mit Lebensmitteln geeignet.

Wood Evolution™

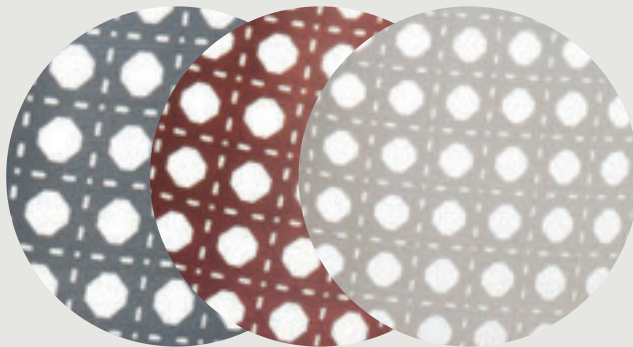

Materiale composito derivante dal legno naturale, il Wood Evolution™ è caratterizzato da una forte resistenza all'usura e agli agenti atmosferici. Brevettato e impiegato nel mondo dello sci, è un materiale sostenibile che elimina l'utilizzo dei classici materiali plastici e permette di sfruttare al massimo spessori molto fini.

Composite material from natural wood, Wood Evolution™ has strong resistance to physical stress and weather agents. Patented and used in the ski world, it is a sustainable material that eliminates the use of classic plastic elements and that makes it possible to make the most of very fine thicknesses.

Matériau composite dérivé du bois naturel, le Wood Evolution™ est caractérisé par une forte résistance à l'usure et aux agents atmosphériques. Breveté et utilisé dans le monde du ski, c'est un matériau durable qui élimine l'utilisation des matières plastiques classiques et permet d'utiliser au maximum des épaisseurs très fines.

Als Verbundmaterial aus Naturholz gewährleistet Wood Evolution™ große Verschleiß- und Witterungsbeständigkeit. In der Skiwelt patentiert und eingesetzt, ist es ein nachhaltiges Material, das den Verzicht auf die klassischen Kunststoffmaterialien und eine maximale Ausnutzung sehr feiner Stärken erlaubt.

Stainless Steel

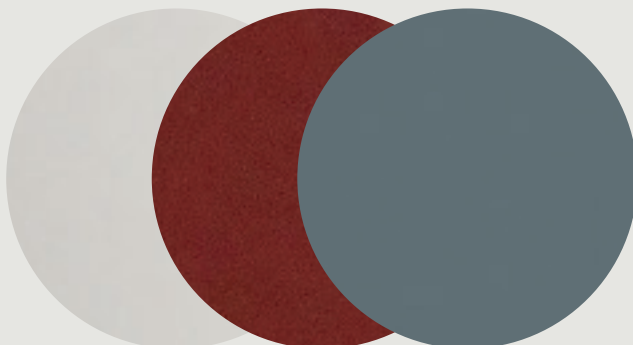

Caratterizzato da stabilità e forza, resistenza alla ruggine e a una maggiore resistenza all'ossidazione e alla corrosione, l'acciaio inox trattato per esterni è ampiamente utilizzato negli arredi outdoor. Il trattamento finale migliora la stabilità agli agenti atmosferici e all'inquinamento.

Characterised by stability and strength, resistance to rust and a greater resistance to oxidation and corrosion, the stainless steel treated for outdoors is widely used in outdoor furnishings. The final treatment improves the stability to weather agents and to pollution.

Caractérisé par stabilité et force, résistance à la rouille et une résistance accrue à l'oxydation et à la corrosion, l'acier inoxydable traité pour l'extérieur est largement utilisé pour le mobilier d'extérieur. Le traitement final améliore la stabilité aux agents atmosphériques et à la pollution.

Geprägt durch Stabilität und Kraft, Rostbeständigkeit und hohe Beständigkeit gegenüber Oxidation und Korrosion, wird der für Außenbereiche behandelte Edelstahl häufig in Outdoor-Umgebungen eingesetzt. Die Endbehandlung verbessert die Witterungs- und Schmutzbeständigkeit.

Brise 23
p. 059, 062, 090, 138

Tech. Spec. → p. 270

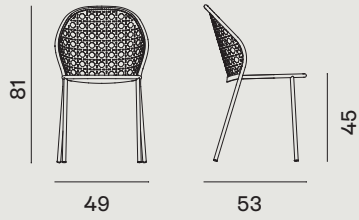

Brise 24
p. 059, 062, 090, 138

Tech. Spec. → p. 270

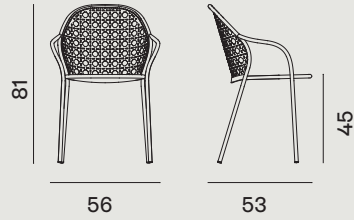

Brise 33
p. 092, 096, 097

Tech. Spec. → p. 258

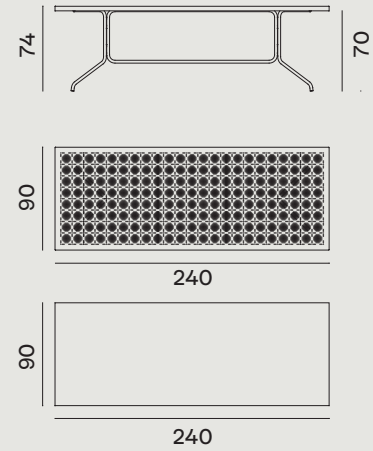

Brise 34

Tech. Spec. → p. 258

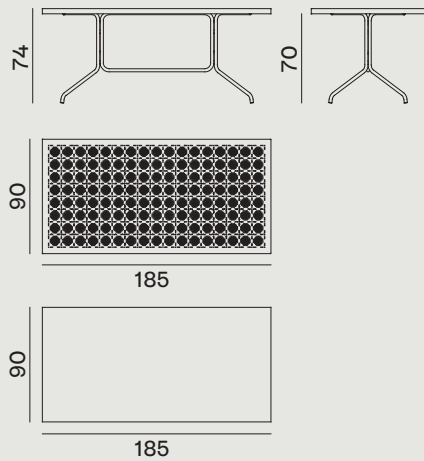

Brise 38
p. 089, 93

Tech. Spec. → p. 258

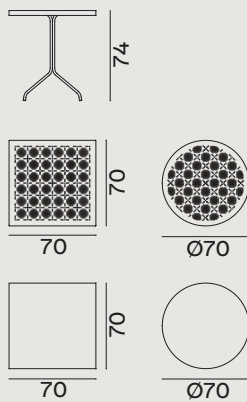

Brise 43
p. 013, 022, 070, 081, 095

Tech. Spec. → p. 286



Brise 44
p. 019, 071, 080, 095, 188

Tech. Spec. → p. 286

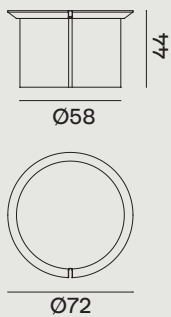

Brise 46
p. 020, 080-081, 095

Tech. Spec. → p. 286

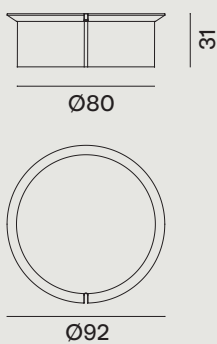

Brise 53
p. 011, 066, 071, 094

Tech. Spec. → p. 288

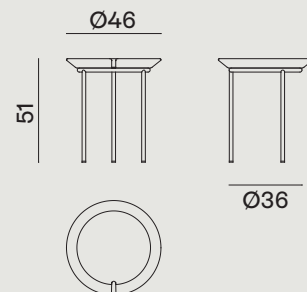

Brise 54
p. 021, 022, 066, 070, 094

Tech. Spec. → p. 288

Brise 56
p. 070, 073, 094

Tech. Spec. → p. 288

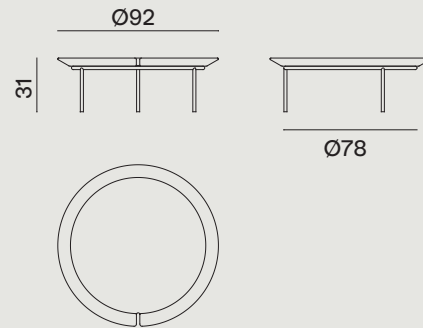
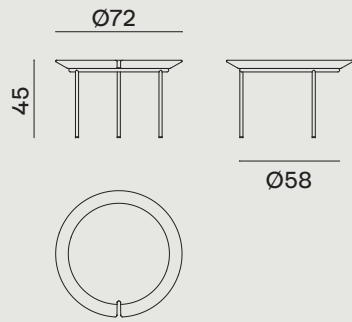



Inout Collection

Design by
Paola Navone

103

Inout Collection

IT. Una collezione ampia e variegata di sedie, sgabelli, poltrone, divani, tavoli e complementi che racconta i tanti modi di Gervasoni di immaginare il tempo all'aria aperta. Suggestioni esotiche si alternano a elementi di sofisticata essenzialità. Ai tradizionali materiali da outdoor, come il legno, lavorato per esaltare le sue naturali qualità, si affiancano materiali di ultima generazione appositamente sviluppati per resistere agli agenti atmosferici ma non per questo meno seducenti e poetici. Anche la tradizione dell'intreccio viene qui reinterpretata per resistere all'acqua e alla luce e per mantenere nel tempo le qualità tecniche e cromatiche che le caratterizzano.



EN.

A broad and varied collection of chairs, stools, armchairs, sofas, tables and accessories portraying the countless ways Gervasoni imagines spending time outdoors. Exotic suggestions are alternated with elements of sophisticated essentiality. Traditional outdoor materials such as wood, worked to enhance its natural properties, are paired with latest generation ones specifically designed to withstand weathering, but no less seductive and poetic. Even the weaving tradition is re-interpreted to resist against water and sunlight, maintaining its technical characteristics and colours unaltered over time.

FR.

Une collection riche et variée de chaises, tabourets, fauteuils, canapés, tables et accessoires qui illustre les nombreuses manières qu'a Gervasoni d'imaginer le temps à l'air libre. Le charme exotique alterne avec un essentialisme sophistiqué. Les matériaux d'extérieur traditionnels tels que le bois, travaillé de manière à révéler ses qualités naturelles, se mêlent à ceux de dernière génération, spécifiquement développés pour résister aux agents atmosphériques, mais tout aussi séduisants et poétiques. La tradition du tressage est là aussi réinterprétée pour pouvoir résister à l'eau et à la lumière et conserver ses qualités techniques et chromatiques.

DE.

Eine umfangreiche und vielfältige Kollektion, die Stühle, Hocker, Sessel, Sofas, Tische und Accessoires umfasst und die vielen Ideen von Gervasoni zum Ausdruck bringt, sich die Zeit im Freien vorzustellen. Exotische Anklänge verbinden sich mit raffinierten minimalistischen Elementen. Neben traditionellen Outdoor-Materialien wie Holz, dessen natürliche Beschaffenheit durch die Verarbeitung betont wird, finden sich Materialien der neuesten Generation, die eigens entwickelt wurden, um gegenüber den Wettereinflüssen beständig zu sein, deswegen aber nicht weniger schön und poetisch sind. Auch die Tradition der Flechtkunst wird hier neu interpretiert, um sowohl gegenüber Wasser und Licht beständig zu sein und die technischen und farblichen Eigenschaften über lange Zeit zu bewahren.





→ Inout 33: Tavolo rettangolare.
Gambe in cemento GFRC bianco,
piano a doghe di teak naturale./
Rectangular table. White GFRC
concrete legs, natural
teak slats top.



Inout 33



Inout 33

Inout 823





Inout 823

Inout 836

↑ Inout 836: Tavolo rotondo.
Base centrale in cemento. Piano
in marmo bianco Carrara/
Round table. Central concrete
base. White Carrara marble top.



Inout 824



Inout 824

Inout 137

↑ Inout 137: Tavolo quadrato.
Base in pietra Piasentina,
colonna centrale in alluminio
Slate, piano in marmo bianco
Carrara. / Square table.
Piasentina stone base, Slate
aluminium central column, white
Carrara marble top.



Inout 883





Inout 35

Inout 823



Inout 883

← Inout 35: Tavolo quadrato.
Base in cemento GFRC grigio
antracite, piano a doghe in
teak naturale./ Square table.
Anthracite grey GFRC concrete
base, natural teak slats top.





← Inout 884:
Lettino/ day-bed.
Materassino/
mattress in Oslo 06-C.

Inout 884

Inout 883

Inout 47



Inout 828





Inout 851

Inout 48

Inout 155



↓ Inout 851: Poltrona/ armchair.
Seduta/seat in Berlin 06-C.
Cuscini/ cushions: 1 40x40 in
Berlin 03-C; 1 60x60 in Oslo
06-C.

← Inout 851: Poltrona/ armchair.
Seduta/seat in Berlin 02-C.
Cuscini/ cushions: 1 40x40 in
Oslo 06-C; 1 60x60 in Berlin
02-C.



→ Inout 853: Divano/ sofa.
Seduta/seat in Cannes 02-C.
Cuscini/ cushions: 3 40x40
in London 08-C, Oslo 06-C;
3 60x60 in Cannes 04-C.





Inout 91, 92

Inout 856

Inout 853

Inout 43

Inout 41

Inout 42



Inout 809

Inout 41, 42





Inout 823

Ghost Out 23

Inout 143



← Inout 143: Tavolo rettangolare allungabile. Base in alluminio Slate, piano in marmo bianco Carrara./ Rectangular extendable table. Slate lacquered aluminum base, white Carrara marble top.

← Ghost Out 23: Sedia/ chair in Oslo 05-C.



Inout 143

Inout 823





Inout 858 R

Inout 858 L

Inout 47

↑ Inout 858 R: Chiasse longue.
Seduta/seat in Lisboa 04-C.
Cuscini/ cushions: 1 80x80 in
London 02-C; 1 60x60 in London
05-C, 1 40x40 in Oslo 07-C.

↑ Inout 858 L: Chiasse longue.
Seduta/seat in Lisboa 04-C.
Cuscini/ cushions: 1 80x80 in
London 02-C; 1 60x60 in Oslo
09-C, 1 40x40 in London 02-C.



Inout 859 L

Inout 859 R

Inout 41, 43

↑ Inout 859 R: Chiasse longue.
Seduta/seat in Aspen 01-C.
Cuscini/ cushions: 1 80x80 in
Oslo 03-C; 1 60x60 in Lisboa
05-C, 1 40x40 in London 02-C.

↑ Inout 859 L: Chiasse longue.
Seduta/seat in Aspen 01-C.
Cuscini/ cushions: 1 80x80 in
Oslo 03-C; 1 60x60 in Lisboa
05-C, 1 40x40 in Oslo 06-C.



Inout 858 L

Inout 858 R

Inout 48, 49







Inout 49

Inout 91, 92

Inout 825



Inout 824

Inout 847



←↑ Inout 847: Tavolo quadrato. Base in alluminio Pearl, piano in marmo bianco Carrara./ Square table. Pearl aluminum central base, white Carrara marble top.



Brise 24

Inout 143

Brise 23



← Inout 143: Tavolo rettangolare.
Base in alluminio Agate, piano in
gres Lecce Stone./ Rectangular
table. Agate lacquered aluminium
base, Lecce Stone stoneware top.



Brise 23





↑→ Inout 81: Lettino/
day-bed in Oslo 04.
Loose cushions: 1 C.
Inout XS in Oslo 01–C.

↑→ Inout 81: Lettino/
day-bed in Oslo 04.
Loose cushions: 1 C.
Inout XS in Lisboa 07–C.

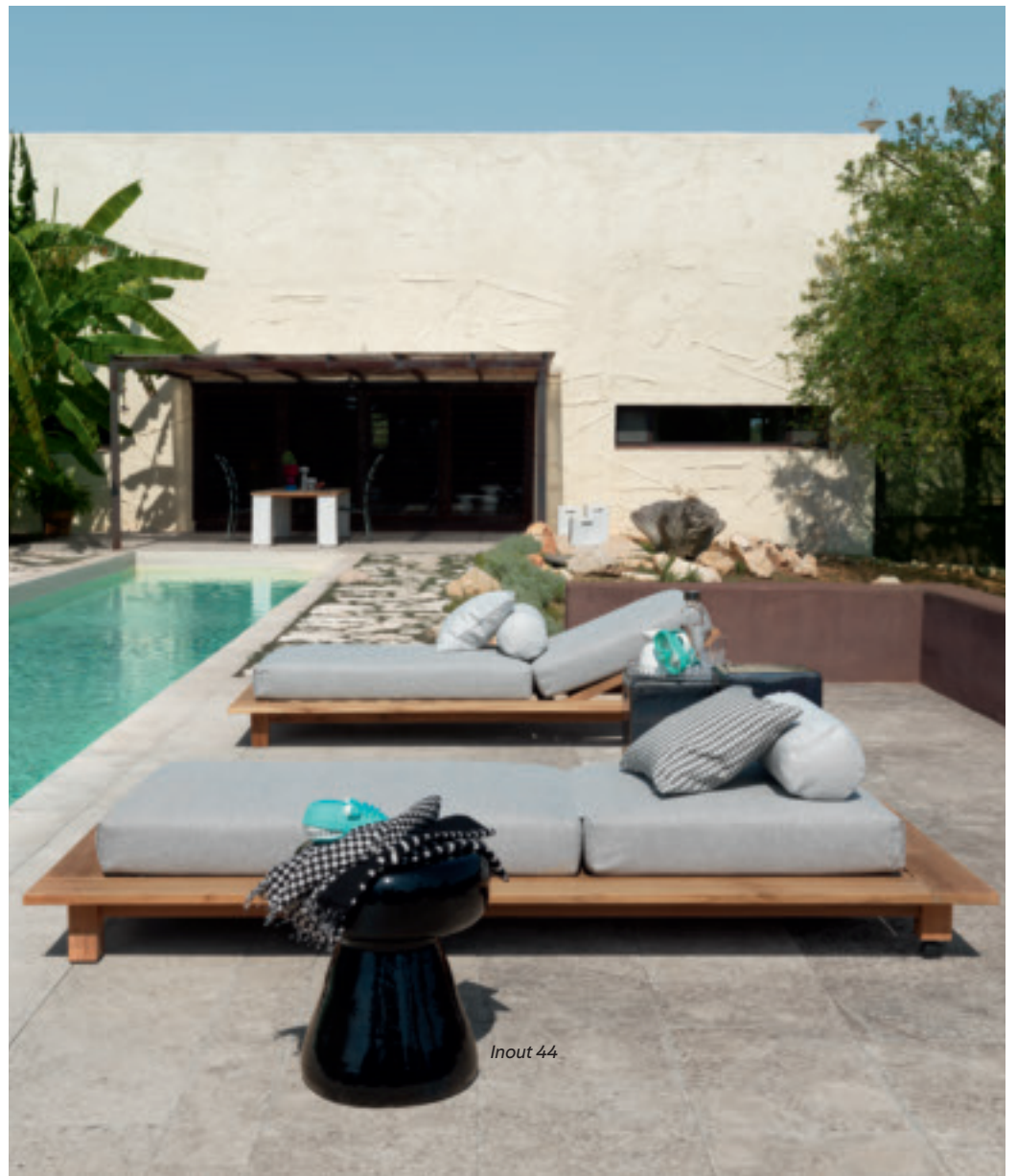

Materials, Colors, Drawings →

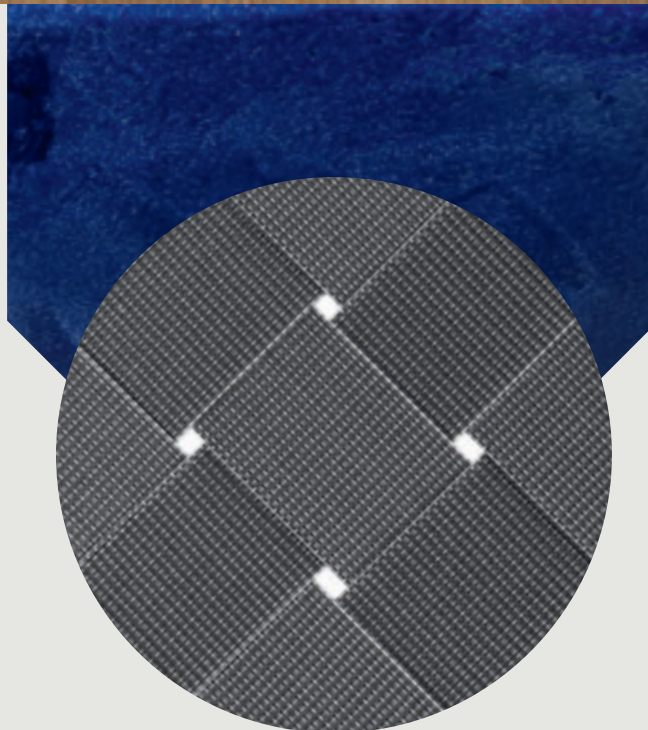
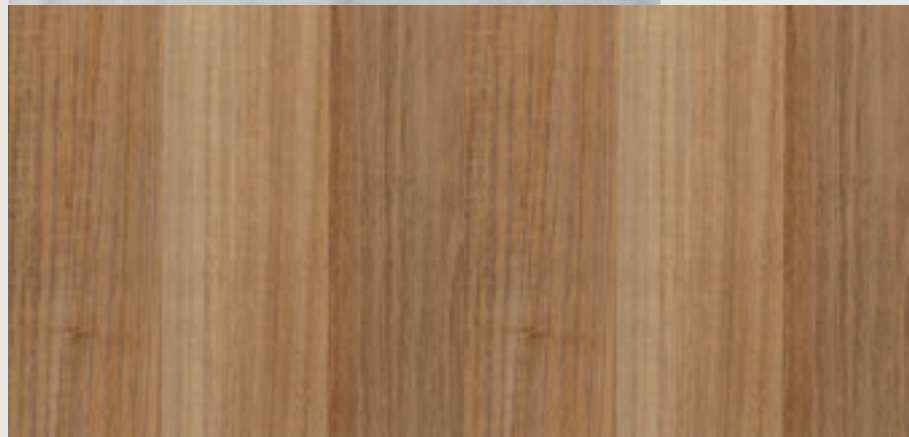
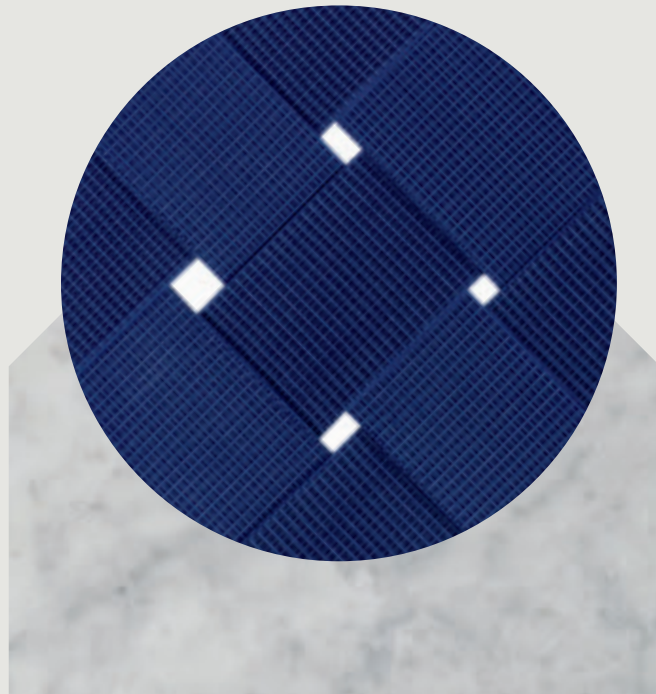

GRFC Concrete

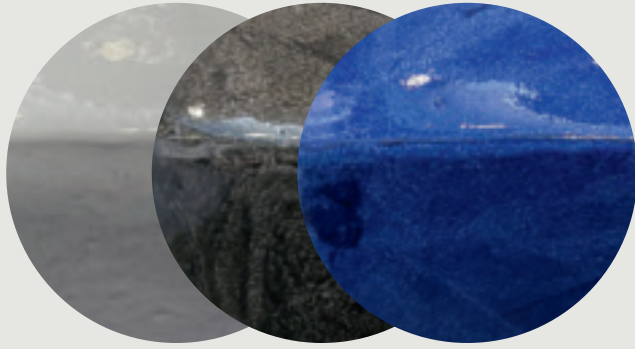

Prodotti realizzati con una miscela di cemento e fibra di vetro verniciati nei colori bianco, nero, blu o grigio antracite con finitura lucida. Il prodotto finale si contraddistingue per una resistenza unica e una maggior durabilità nel tempo.

Les produits sont réalisés avec un mélange de béton et de fibre de verre en blanc, noir, bleu ou gris anthracite, finition brillante. Le produit final se distingue par sa résistance unique et une plus grande durabilité dans le temps.

Products made with a mixture of concrete and glass fiber, white, black, blue or anthracite gray glossy lacquered. The final product stands out for its unique strength and for a greater durability over time.

Die Produkte bestehen aus einer Mischung von Zement und Glasfaser, weiß, schwarz, blau oder anthrazit grau glänzend lackiert. Das Material zeichnet sich durch seine einzigartige Festigkeit sowie eine längere Lebensdauer aus.

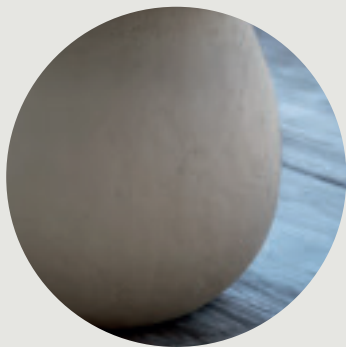

Prodotti realizzati con una miscela di cemento e fibra di vetro. Il cemento GFRC si contraddistingue per una resistenza unica e una maggior durabilità nel tempo. Gli articoli vengono finiti con una verniciatura grigio opaco. La texture del cemento imita la matericità data dalle crepe che si formano su una superficie nel tempo.

Les produits sont réalisés avec un mélange de ciment et de fibre de verre et sont laqués en gris mat. Le produit final se distingue par sa résistance unique et une plus grande durabilité. La finition imite les craquelures qui se forment normalement sur la surface du béton au fil du temps.

Products made from fusion of concrete and glass fiber. The final product stands out for its unique strength and for a greater durability over time. The items are finished with a matt grey paint. The final texture draws the material effect of the cracks that form on a surface over time.

Die Produkte bestehen aus einer Mischung von Zement und Glasfaser, matt grau lackiert. Das Material zeichnet sich durch seine einzigartige Festigkeit sowie eine längere Lebensdauer aus. Die Ausführung mit dem Craqueureffekt ahmt die Risse nach, die sich normalerweise im Laufe der Zeit auf einer Betonoberfläche bilden.

Aluminum

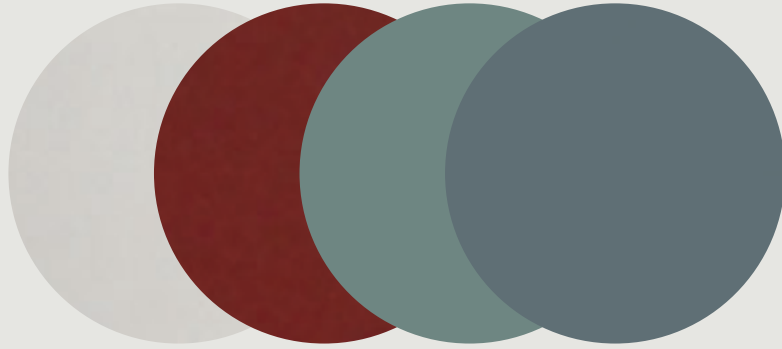

Oltre che espressivo ed ecologico, l'alluminio è un metallo unico per qualità tecniche. Tre volte più leggero dell'acciaio, e stabile nel tempo, resistente agli agenti atmosferici e di facile manutenzione. In più è riciclabile e può essere riutilizzato all'infinito, senza la minima alterazione delle sue proprietà tecniche e meccaniche. L'alluminio utilizzato nella collezione è oggetto di uno specifico pre-trattamento antisalino che inibisce il naturale processo di ossidazione. Il successivo procedimento di verniciatura a polvere aumenta la resistenza alla corrosione e protegge il metallo anche da graffi e scheggiature.

In addition to being expressive and ecological, aluminum is also a unique metal in terms of technical qualities. Three times lighter than steel, it offers stability over time, resistance to the weathering and easy maintenance. Moreover, it is recyclable and can be reused an infinite number of times without the slightest alteration of its technical and mechanical properties. The aluminum of the collection has been processed using a specific anti-saline pretreatment, which inhibits the natural oxidation process. The subsequent powder-coating process increases resistance to corrosion while also protecting the metal against scratches and chipping.

En plus d'être expressif et écologique, l'aluminium est un métal aux qualités techniques uniques. Trois fois plus léger que l'acier, il est stable dans le temps, résistant aux agents atmosphériques et facile d'entretien. Par ailleurs, il est recyclable et peut être réutilisé indéfiniment, sans la moindre altération de ses propriétés techniques ou mécaniques. L'aluminium employé dans cette collection fait l'objet d'un prétraitement anti-salin qui inhibe le processus naturel d'oxydation. L'étape successive, celle du vernissage en poudre, augmente la résistance à la corrosion et protège également le métal des rayures et des éclats.

Aluminium ist nicht nur ausdrucksvoll und umweltfreundlich, sondern auch einzigartig, was seine technischen Eigenschaften angeht. Es ist dreimal leichter als Stahl, beständig im Laufe der Zeit, widersteht atmosphärischen Einflüssen und ist leicht zu pflegen. Darüber hinaus ist es recycelbar und kann immer weiter verwendet werden, ohne die geringste Beeinträchtigung seiner technischen und mechanischen Eigenschaften. Das für die Kollektion verwendete Aluminium ist Gegenstand einer besonderen Behandlung, die es gegenüber Salz beständig macht und den natürlichen Oxydationsprozess verhindert. Die folgende Pulverbeschichtung erhöht die Korrosionsbeständigkeit und schützt das Metall vor Kratzern und Absplitterungen.

Elastic Belt

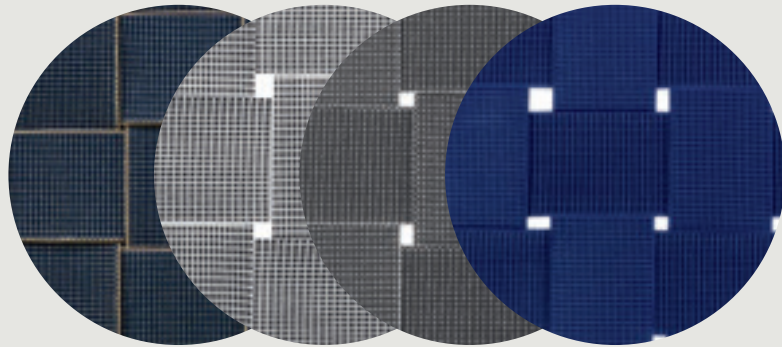

La cinghia elastica utilizzata per la collezione è un prodotto innovativo sviluppato per l'outdoor. La struttura a base di gomma sintetica e propilene trattato per uso esterno garantisce la durata e la resistenza nel tempo a fenomeni di scolorimento e deterioramento provocati da agenti atmosferici e inquinanti. Il processo di fabbricazione altamente specializzato garantisce la rispondenza del prodotto ai requisiti di elasticità e tenuta.

The elastic belt used in the collection is an innovative product specifically developed for outdoor furniture. The structure, made from synthetic rubber and propylene treated for outdoor use, guarantees durability and resistance over time against fading and deterioration caused by the weathering and pollutants. The highly specialized manufacturing process ensures the product satisfies requirements of elasticity and hold.

La sangle élastique utilisée pour cette collection est un produit innovant développé pour l'extérieur. Sa structure, à base de caoutchouc synthétique et de propylène traité pour un usage extérieur, garantit sa durée et sa résistance dans le temps aux phénomènes de décoloration et de détérioration provoqués par les agents atmosphériques et polluants. Le procédé de fabrication hautement spécialisé permet au produit de répondre à des exigences d'élasticité et de tenue.

Die für die Kollektion verwendeten elastischen Gurte sind ein innovatives Produkt, das für die Verwendung im Freien entwickelt wurde. Die Struktur aus synthetischem Gummi und für den Outdoor-Gebrauch behandeltem Propylen gewährleistet Lebensdauer und Widerstandsfähigkeit gegenüber atmosphärischen Einflüssen und Umweltbelastung. Dank des hochspezialisierten Herstellungsprozesses verbindet das Produkt Elastizität und Festigkeit.

Marble

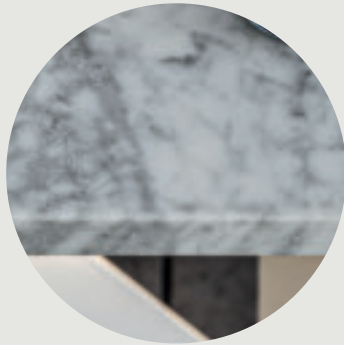

Il più classico dei marmi italiani, ha in sé una bellezza e un'eleganza senza tempo. Alle qualità estetiche, abbina caratteristiche strutturali, fisiche e morfologiche che lo rendono naturalmente compatto, resistente all'usura e idoneo al contatto con gli alimenti. Il marmo utilizzato in collezione e trattato con impregnante protettivo trasparente opaco.

The most classic Italian marble is in itself a product of beauty and timeless elegance. These aesthetic qualities are combined with structural, physical and morphological characteristics making it naturally compact, resistant to wear and suitable for dining purposes. The marble used in the collection is treated with a clear matt protective impregnating agent.

Le plus classique des marbres italiens porte en lui une beauté et une élégance intemporelles. Il allie a ses qualités esthétiques des propriétés structurelles, physiques et morphologiques qui le rendent naturellement solide, résistant a l'usure et adapte au contact avec les aliments. Le marbre utilise dans cette collection est protégé a l'aide d'un imprégnant transparent opaque.

Der berühmteste italienische Marmor zeichnet sich durch zeitlose Eleganz und Schönheit aus. Neben seinen ästhetischen Qualitäten verbindet er strukturelle, physische und morphologische Eigenschaften, dank derer er von Natur aus kompakt, widerstandsfähig und für den Kontakt mit Lebensmitteln geeignet ist. Der für die Kollektion verwendete Marmor wird mit einer matt-transparenten Schutzschicht versehen.

Lecce Stone stoneware



Ispirato al colore e alla matericità della tradizionale roccia calcarea Salentina, il gres Lecce Stone ha uno spessore di 6 mm ed è caratterizzato da una superficie compatta, refrattaria al calore e particolarmente resistente agli agenti atmosferici, all'umidità e alle muffe. Lavabile con detergenti comuni e facile da mantenere per le qualità antimacchia della superficie, il gres Lecce stone è anche un materiale idoneo al contatto con alimenti.

Inspired by the color and texture of the traditional Salentine limestone rock, Lecce Stone stoneware is 6 mm thick and it is characterized by a compact, heatproof surface, particularly resistant to the weathering, moisture and mould. Washable using common household detergents and easy to maintain thanks to the stain resistant surface, Lecce Stone stoneware is also a material perfect for dining purposes.

Le grès Lecce Stone s'inspire à la couleur et la matérialité du calcaire traditionnel du Salento. Le plateau d'une épaisseur de 6 mm présente une surface compacte, réfractaire à la chaleur et particulièrement résistante aux agents atmosphériques, à l'humidité et aux moisissures. Lavable avec des détergents ordinaires et facile à entretenir en raison de ses propriétés antitaches et anti-rayures, le grès Lecce Stone est également adapte au contact avec les aliments.

Farbe und Materialität des traditionellen Salento-Kalksteins sind Quelle der Inspiration für das Feinsteinzeug Lecce Stone. Die 6 mm dicke Platte zeichnet sich durch eine kompakte, hitzebeständige und gegenüber atmosphärischen Einflüssen, Feuchtigkeit und Schimmel besonders beständige Oberfläche aus. Sie kann mit handelsüblichen Reinigungsmitteln gesäubert werden und ist dank der schmutzabweisenden und kratzfesten Beschaffenheit leicht zu pflegen. Feinsteinzeug eignet sich darüber hinaus für den direkten Kontakt mit Lebensmitteln.

Crackle Concrete



La finitura ricorda la craquelure che il tempo disegna sui materiali. L'effetto è ottenuto sovrapponendo più strati di vernice fra i quali viene steso un reagente che solleva parte dello strato più superficiale, lasciando intravedere quello sottostante. L'effetto craquelure che si ottiene dopo l'asciugatura e la cottura del cemento è sempre diverso e rende ogni base un pezzo unico.

This finish recalls the craquelure that appears on materials over time. The effect is obtained by overlapping multiple layers of paint, among with a reagent is spread, which lifts up partially the uppermost layer, bringing the underlying layer into view. The craquelure effect is obtained after the cement is dried and cooked. It is always different and makes each base a unique piece.

Cette finition rappelle les craquelures que le temps dessine sur les matériaux. L'effet est obtenu en superposant plusieurs couches de vernis entre lesquelles est appliqué un réactif qui soulève une partie de la couche la plus superficielle pour laisser entrevoir celle d'en dessous. Les craquelures que l'on obtient après séchage et cuisson du béton sont toujours différentes, ce qui rend chaque piètement unique.

Die Optik beruht auf dem Craquelure-Effekt, dem Materialien durch Alterung unterliegen. Er entsteht, indem mehrere Schichten Lack übereinandergelegt werden, in die ein Reagens eingefügt wird, das einen Teil der obersten Schicht anhebt, so dass die darunterliegenden Schichten zum Vorschein kommen. Da der Craquelure-Effekt, der nach der Trocknung und dem Brennen des Betons auftritt, jedesmal anders ist, ist jedes Gestell ein Einzelstück.

Teak



Il Teak (*Tectona grandis*) è uno dei più pregiati legni tropicali con eccezionali caratteristiche di durezza, duttilità e resistenza agli agenti atmosferici, all'umidità, alla salsedine. La sua particolarità deriva dalla presenza di una resina oleosa che ne aumenta naturalmente il grado di impermeabilità e di resistenza anche a insetti e parassiti. Il Teak naturale utilizzato per realizzare la collezione proviene da foreste delle regioni tropicali del sud-est asiatico.

Le teck (*Tectona Grandis*) est l'un des bois exotiques les plus prisés. Il possède d'incroyables propriétés de robustesse, de ductilité et de résistance aux agents atmosphériques, à l'humidité et au sel. Sa particularité lui vient de son oléorésine qui augmente naturellement son imperméabilité ainsi que sa résistance aux insectes et parasites. Le teck naturel utilisé pour réaliser cette collection provient de forêts des régions tropicales du sud-est asiatique.

Teak (*Tectona grandis*) is one of the most precious tropical woods, having exceptional characteristics of hardness, ductility and resistance to the weathering, moisture and salt. Its uniqueness comes from an oily resin which naturally improves its impermeability and resistance, even to insects and parasites. The natural teak used to develop the collection originates from forests in the tropical regions of Southeast Asia.

Teak (*Tectona grandis*) ist eines der kostbarsten Tropenholzer und zeichnet sich durch außergewöhnliche Härte, Geschmeidigkeit und Widerstandsfähigkeit gegen atmosphärische Einflüsse, Feuchtigkeit und Salz aus. Seine besonderen Eigenschaften gehen auf ein öliges Harz zurück, das für seine natürliche Impermeabilität und Resistenz gegen Insekten und Parasiten sorgt. Das für die Kollektion verwendete Teak stammt aus Wäldern im tropischen Südostasien.

Upholstery



L'imbottitura dei cuscini di seduta e schienale è realizzata in poliuretano espanso per renderla più compatta e resistente. La perfetta impermeabilizzazione delle imbottiture è garantita dal rivestimento con fodere in poliestere, trattate con specifici prodotti idrofughi e idrorepellenti, e dalle cuciture termosaldate. Tutti i cuscini e le parti imbottite in collezione sono sfoderabili.

Le garnissage des assises et des dossiers est réalisé en polyuréthane expansé afin de les rendre plus compacts et résistants. Il est parfaitement imperméabilisé grâce à des housses en polyester aux propriétés hydrofuges et hydrophobes et grâce aux coutures thermosoudées. Tous les coussins et les parties rembourrées de la collection sont déhoussables.

The padding of the seat and back cushions is made of polyurethane foam to improve their compactness and resilience. The perfect water-repellence is guaranteed by the polyester cushion covers, treated with specific waterproof and water-repellent products, and the heat welded seams. All the cushions and upholstered elements of the collection have removable covers.

Die Polsterung der Sitze und Rückenlehnen wird aus Polyurethanschaum hergestellt, wodurch sie besonders kompakt und widerstandsfähig sind. Die perfekte Abdichtung der Polsterung wird durch die Polyester Überzüge garantiert, die mit speziellen wasserabweisenden Produkten behandelt und mit Thermobandierung versehen sind. Sämtliche Kissen und Polster Elemente der Kollektion sind abziehbar.

Inout 33
p. 106-107, 108, 109, 221

Tech. Spec. → p. 233

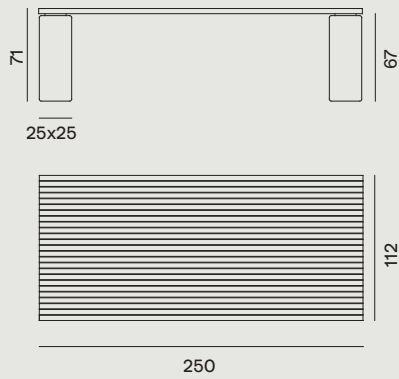

Inout 34

Tech. Spec. → p. 233

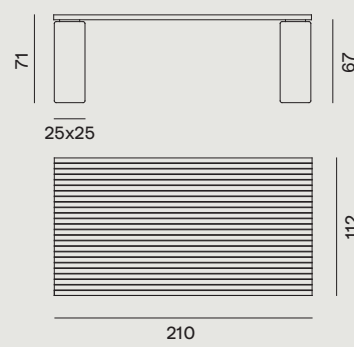

Inout 35
p. 114

Tech. Spec. → p. 233

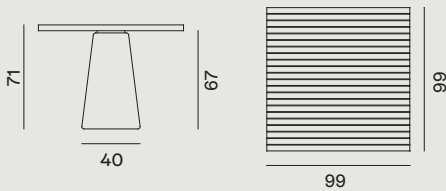

Inout 41

Tech. Spec. → p. 277

p. 042, 123, 124, 131

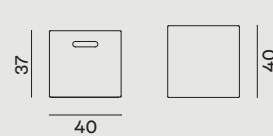

Inout 42

Tech. Spec. → p. 277

p. 042, 049, 123, 124, 177

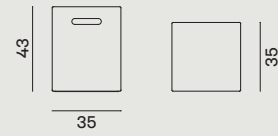

Inout 43
p. 042, 123, 177

Tech. Spec. → p. 277

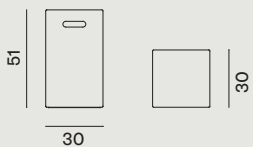

Inout 44

Tech. Spec. → p. 277

p. 046, 143, 188, 205

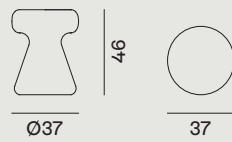

Inout 47

Tech. Spec. → p. 280

p. 038, 116-117, 171, 174

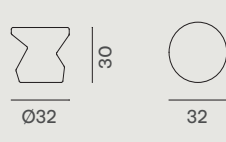

Inout 48

Tech. Spec. → p. 280

p. 038, 120, 179, 212

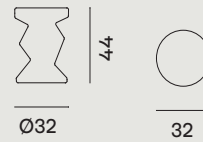

Inout 49
p. 038, 116, 135, 188

Tech. Spec. → p. 280

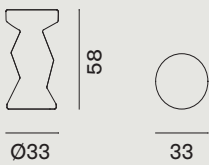

Inout 81
p. 142, 143

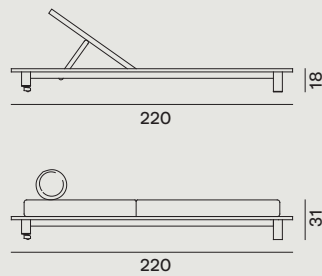

Inout 91
p. 047, 122, 135, 190

Tech. Spec. → p. 277



Inout 92
p. 046, 122, 135, 190



1
Ø20x50

Inout 137
p. 111, 224, 225

Tech. Spec. → p. 236

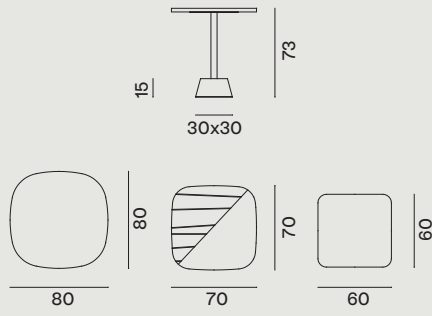

Inout 143
p. 126-127, 128, 138-139, 140

Tech. Spec. → p. 240

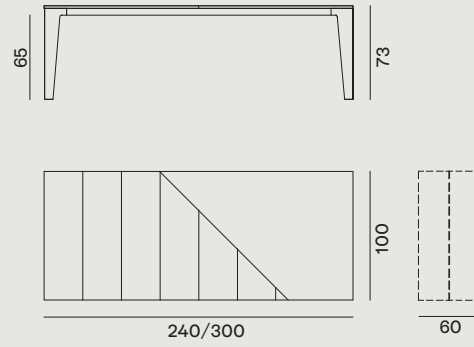

Inout 144

Tech. Spec. → p. 240

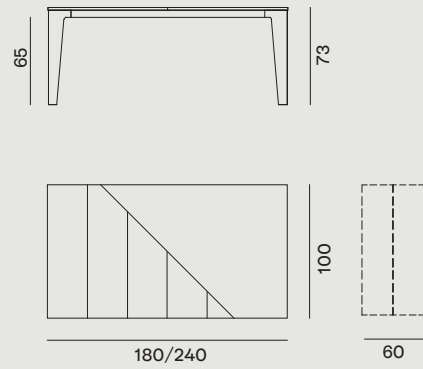

Inout 155
p. 120

Tech. Spec. → p. 240

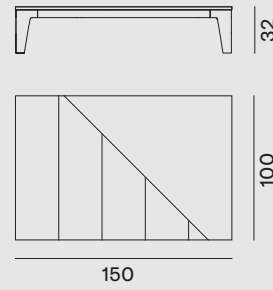

Inout 809
p. 124, 125

Inout 823
p. 096, 097, 106, 110, 114, 126

Tech. Spec. → p. 263

Inout 824
p. 048, 097, 110, 112, 136

Tech. Spec. → p. 263

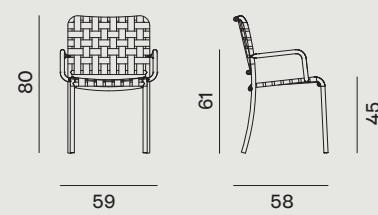
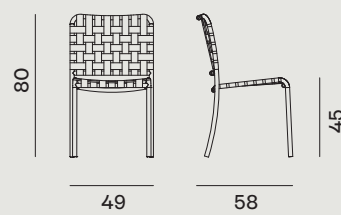
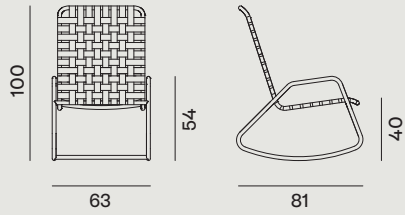

Inout 825
p. 134, 135

Inout 828
p. 118, 119

Tech. Spec. → p. 263

Inout 834

Tech. Spec. → p. 244

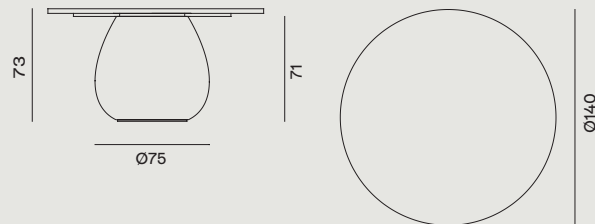
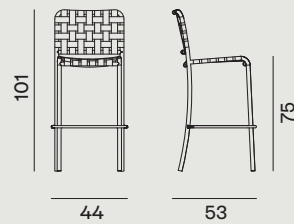
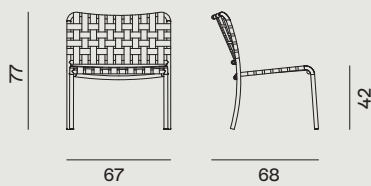

Inout 836
p. 110, 218, 222

Tech. Spec. → p. 244

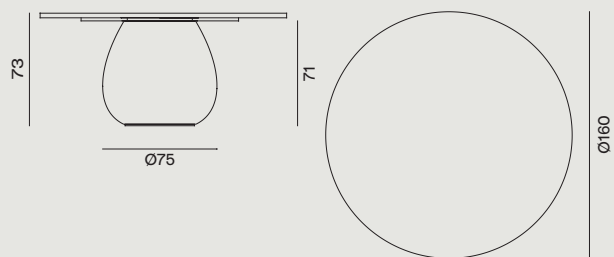

Inout 837
p. 266

Tech. Spec. → p. 246

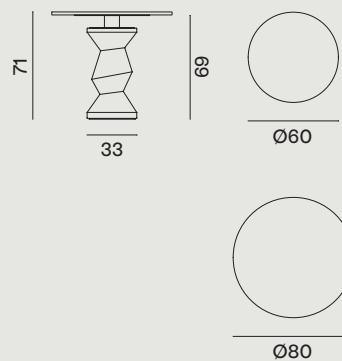

Inout 838
p. 194, 209

Tech. Spec. → p. 246

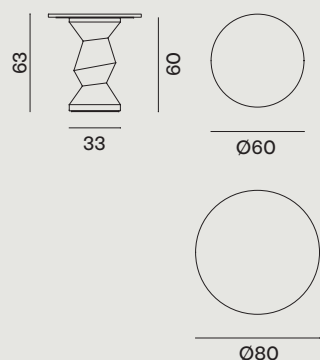

Inout 847
p. 136, 137, 196, 197

Tech. Spec. → p. 248

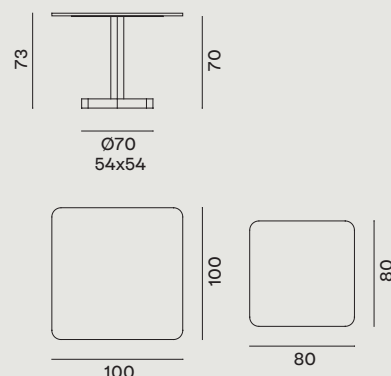

Inout 848

Tech. Spec. → p. 248

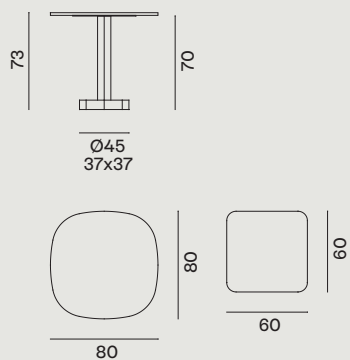

Inout 851
p. 120, 121

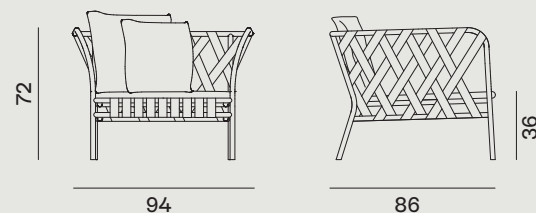

Inout 852
p. 122-123

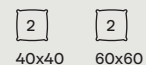
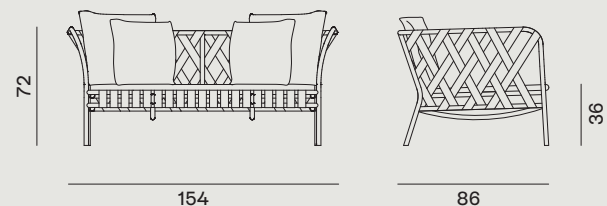

Inout 853

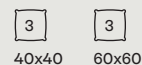
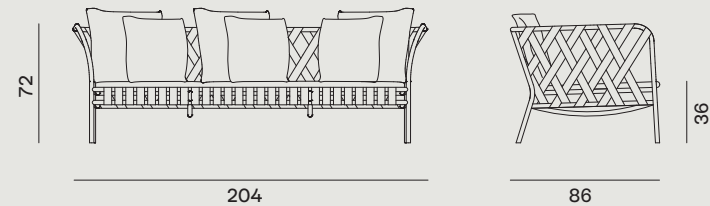

Inout 855
p. 106-107, 109

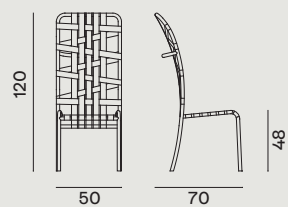

Inout 856
p. 102, 105, 122-123

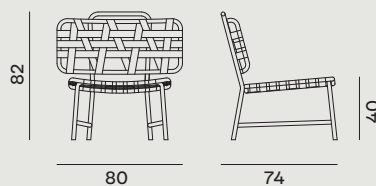

Tech. Spec. → p. 263

Inout 858 L-R
p. 130-131, 132

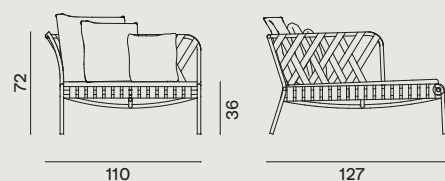

Inout 859 L-R
p. 130-131, 133

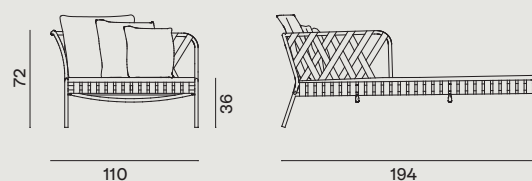

Inout 883
p. 112, 115, 116, 153

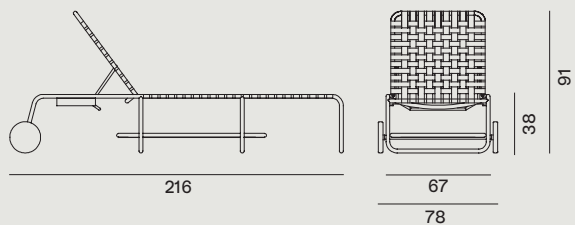

Inout 884
p. 116-117, 153

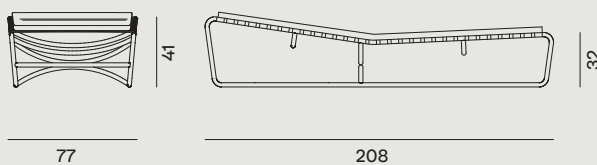

C. Inout XS

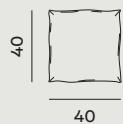

C. Inout PI

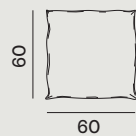

C. Inout GR

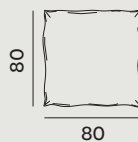





Guna Collection

Design by
Chiara Andreatti

155

Guna Collection

IT. Chiara Andreatti firma la collezione di arredi outdoor Guna composta da tappeti, day-bed charpoy e tavolini dalla forte ispirazione multi-etnica. Il nome Guna racchiude il significato profondo della collezione: un intreccio di filati, maglie e texture ma anche di ispirazioni, relazioni e culture che sono alla base del progetto della designer.



EN.

Chiara Andreatti has designed the Guna outdoor furniture collection consisting of rugs, day-bed charpoy and coffee tables with a strong, multi-ethnic inspiration. The name Guna encapsulates the deep meaning behind the collection: interweaving yarns, knits and textures, as well as inspirations, relationships and cultures are the basis of the designer's project.

FR.

Chiara Andreatti signe la collection de mobilier d'extérieur Guna qui se compose de tapis, des bancs indiens charpoy et des tables basses d'inspiration fortement multiethnique. Le nom Guna représente le sens profond de la collection: un entrelacs de fils, de mailles et de textures mais aussi d'inspirations, de relations et de cultures qui est à la base du projet de la styliste.

DE.

Chiara Andreatti zeichnet für die Outdoor-Möbel-Kollektion Guna aus Teppichen, Charpoy -Daybeds und Beistelltischen mit starker multiethnischer Inspiration verantwortlich. Der Name Guna birgt die tiefere Bedeutung der Kollektion: eine Verflechtung aus Garnen, Maschen und Texturen, aber auch aus Inspirationen, Beziehungen und Kulturen an der Basis des Entwurfs der Designerin.



Guna 02

Guna 01



Guna 01

Guna 11

↑ Guna 01 Natural: Day-bed in Odessa 01-C.
 Loose cushions: 1 C. Guna RUL M in Madrid 05-C; 1 C. Guna XS in Madrid 04-C.
 ↑ Guna 02 Blue: Day-bed in Odessa 05-C.

↑ Guna 01 Blue: Day-bed in Oslo 05-C.
 Loose cushions: 1 C. Guna RUL M in Odessa 01-C; 1 C. Guna XS in Aspen 02-C.
 ↑ Guna 02 Natural: Day-bed in Odessa 01-C.



Rug Guna 02 Blue

Guna 02



Guna 12



Guna 01

Rug Guna 03 Blue



↑ Guna 01 Natural: Day-bed in Madrid 04-C.
 Loose cushions: 1 C. Guna RUL M in Madrid 05-C; 1 C. Guna XS in Aspen 03-C.

↑ Rug Guna 02 Blue: Tappeto/ Carpet.
 ↑ Rug Guna 01 Blue: Tappeto/ Carpet.
 ↑ Rug Guna 03 Blue: Tappeto/ Carpet







Rug Guna 01 Red

Rug Guna 01 Blue



Rug Guna 02 Natural

Rug Guna 03 Red

Materials, Colors, Drawings →



Nautical Rope



L'intreccio è realizzato a mano con corda in poliestere rivestita con fibre acriliche. Resistente all'acqua e alla luce solare, la corda nautica è un materiale resiliente alla deformazione e anche bagnato non perde resistenza allo sforzo ripetuto.

Le tressage est réalisé à la main avec de la corde en polyester revêtue de fibres acryliques. Résistante à l'eau et à la lumière solaire, la corde nautique est un matériau résilient à la déformation et qui, même mouillé, ne perd pas sa résistance à l'effort répété.

The weave is made by hand with polyester rope covered in acrylic fibres. Resistant to water and to direct sunlight, the nautical rope is a material resistant to deformation and even when wet, it is not less resistant to repeated stress.

Die Verflechtung wird von Hand mit einem mit Acrylfasern überzogenen Polyesterseil hergestellt. Das wasser- und sonnenlichtbeständige Schiffsseil ist ein verformungsfestes Material, das auch im nassen Zustand nicht an Widerstand gegen wiederholte Beanspruchung verliert.

Millgres

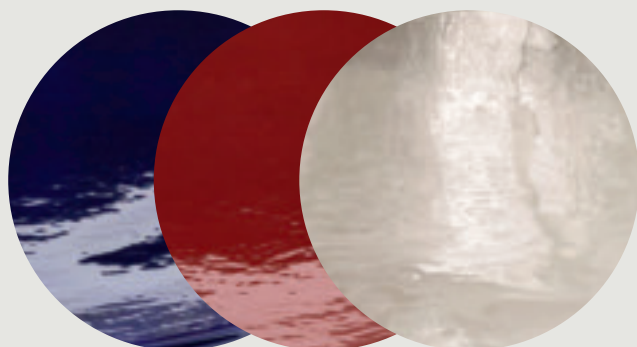

La resistenza agli agenti atmosferici e all'umidità rende il Millgres un materiale perfetto per il mondo outdoor. Inoltre, la facilità di manutenzione per le qualità antimacchia e di lavaggio con detergenti comuni, lo rendono idoneo anche al contatto con gli alimenti.

Grâce à sa résistance aux agents atmosphériques et à l'humidité, le Millgres est un matériau parfait pour la vie à l'extérieur. Grâce à sa facilité d'entretien, à ses qualités antimacchia et de nettoyage avec un détergent ordinaire, il est adapté au contact avec les aliments.

The resistance to weather agents and to humidity makes Millgres a perfect material for the outdoor world. Furthermore, the easy maintenance thanks to its stain-proof qualities and ability to be washed with common detergents make it also suitable to be used for foods.

Die Witterungs- und Feuchtigkeitsbeständigkeit macht Millgres zu einem perfekten Material für die Outdoor-Welt. Außerdem machen es die einfache Instandhaltung dank seiner fleckenabweisenden Eigenschaften und die einfache Reinigung mit herkömmlichen Putzmitteln auch für den Kontakt mit Lebensmitteln geeignet.

Iroko



Il legno Iroko è una specie particolarmente dura proveniente dalle foreste dei paesi dell'Africa equatoriale. Essendo un legno resinoso è per natura protetto dall'acqua e dall'umidità. Ha notevoli qualità meccaniche, come la particolare resistenza alla flessione. L'iroko utilizzato nella collezione è legno massello stabilizzato in forni di essiccazione e successivamente oliato, procedimenti che, oltre ad aumentarne la compattezza, ne esaltano anche le venature o sfumature di colore.

L'iroko est une espèce particulièrement dure provenant des forêts d'Afrique équatoriale. En tant que résineux, il est naturellement protégé de l'eau et de l'humidité. Il possède de remarquables propriétés mécaniques, comme sa résistance particulière à la flexion. L'iroko utilisé dans cette collection est un bois massif séché au four et après huilé, ce qui non seulement augmente sa compacité, mais exalte également ses veines ou ses nuances de couleur.

Iroko wood is a particularly hard species from the forests of tropical Africa. Being a resinous wood, it is naturally protected against water and moisture. It features impressive mechanical qualities, such as resistance to bending. The Iroko used in the collection is a solid wood stabilised in drying ovens and oiled afterwards, procedures which not only improve its compactness but also highlights grains and shades of colour.

Iroko ist ein besonders hartes Holz aus den Wäldern Äquatorialafrikas. Da es sich um ein harzreiches Holz handelt ist es von Natur aus wasser- und feuchtigkeitsfest. Es besitzt außergewöhnliche mechanische Eigenschaften, darunter die besondere Festigkeit. Bei dem für diese Kollektion verwendete Iroko, handelt es sich um ein Massivholz, das in Trockenöfen stabilisiert und danach geölt wird, was ihm nicht nur mehr Dichte verleiht, sondern auch seine Maserung und die Farbnuancen hervorhebt.

Guna 01
p. 157, 158-159, 160

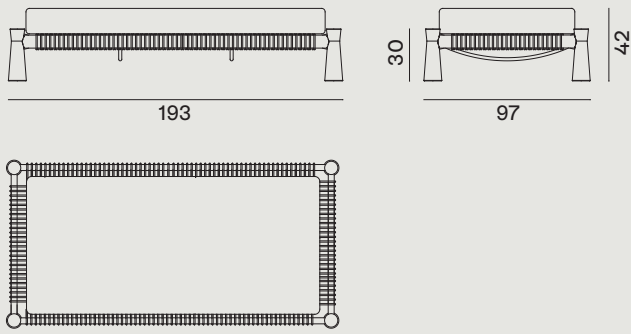

Guna 02
p. 157, 158-159, 160

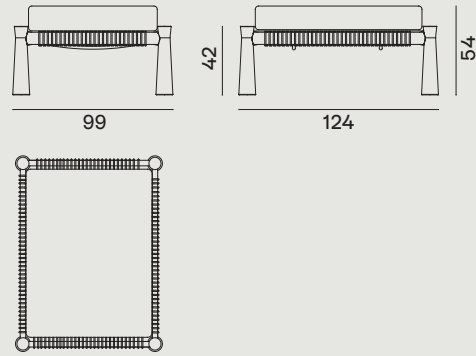

Guna 11
p. 016, 074, 154, 158, 161

Tech. Spec. → p. 284

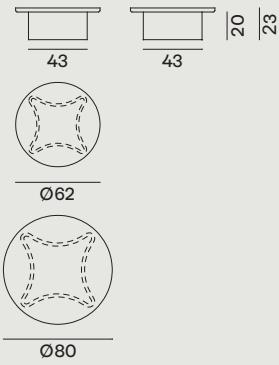

Guna 12
p. 016, 028, 079, 158, 161

Tech. Spec. → p. 284

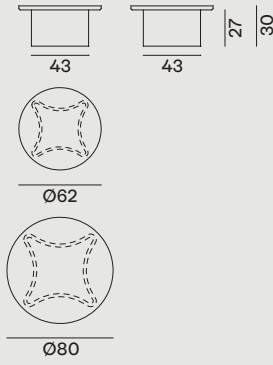

Rug Guna 01
p. 037, 080, 158, 162

Tech. Spec. → p. 298

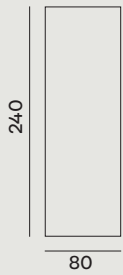

Rug Guna 02
p. 092, 158, 167, 188, 206

Tech. Spec. → p. 298

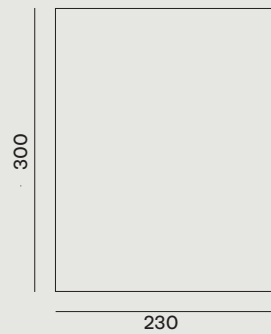

Rug Guna 03
p. 019, 037, 159, 162, 167

Tech. Spec. → p. 298

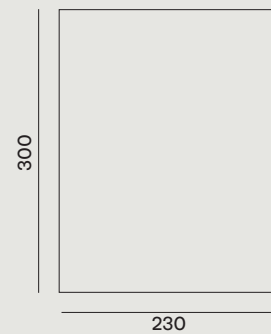

C. Guna XS

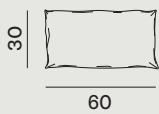

C. Guna Rul M

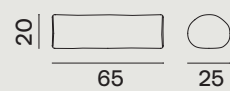

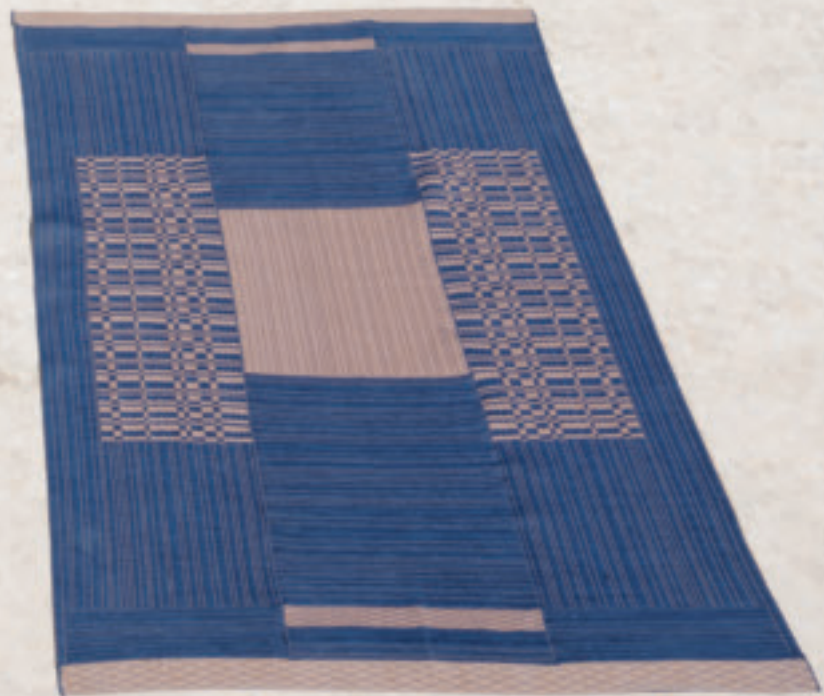



Inout 700 Collection

Design by
Paola Navone

Inout 700 Collection

IT. Il colore caldo e le sfumature dell'Iroko donano alla collezione un'eleganza naturale.

I divani, le poltrone e la sedia a dondolo sono avvolgenti e confortevoli grazie ai cuscini di seduta alti e squadrati come materassi e ai soffici cuscini di schienale.



EN.

The warm tones and shades of Iroko offer the collection a natural elegance.

The sofas, armchairs and rocking chair are enveloping and comfortable thanks to the high seat cushions, squared like mattresses, and the soft back cushions.

FR.

La couleur chaude et les nuances de l'iroko apportent à cette collection une élégance naturelle.

Les canapés, les fauteuils et la chaise à bascule sont accueillants et confortables grâce à d'épais coussins d'assise et à de moelleux coussins de dos.

DE.

Die warme Farbe und schönen Nuancen von Iroko schenken dieser Kollektion natürliche Eleganz. Die Sofas, Sessel und der Schaukelstuhl sind dank der hohen, quadratischen Sitzpolster, die kleinen Matratzen ähneln, und der weichen Rückenissen besonders einladend und komfortabel.



Inout 709

Inout 47

Rug Eco 02 Natural



↑ Inout 709: Dondolo/
Rocking chair. Seduta/seat
in London 04-C. Cuscini/
cushions: 1 65x80
in London 04-C, 1 65x50
in London 05-C.

↑ Inout 703: Divano/
sofa. Seduta/seat in Aspen 04 -C
(stitching Grigio Scuro).
Cuscini/ cushions: 5 50x115 in
Lisboa 02-C; 2 65x50 in Lisboa
06-C (stitching Grigio Scuro).



Heiko 43

Rug Eco 02 Natural

Inout 701

↑ Rug Eco 02 Natural:
Tappeto/ Carpet.
↑ Rug Guna 02 Red:
Tappeto/ Carpet.

↑ Inout 701: Poltrona/ armchair.
Seduta/seat in Aspen 04-C
(stitching Grigio Scuro).
Cuscini/ cushions: 2 50x115 in
Lisboa 02-C, Aspen 04-C;
1 65x50 in Lisboa 06-C (stitching
Grigio Scuro).



Inout 742

Inout 47

Inout 707



← Inout 707: Poltrona/ Armchair.
Seduta/seat in Dublin 03-C
(stitching Grigio Chiaro). Cuscini/
cushions: 2 65x50 in Dublin
02-C, Aspen 04-C (stitching
Grigio Chiaro).





↑ Inout 701: Poltrona/ armchair. Seduta/seat in Oslo 09-C (stitching Red). Cuscini/ cushions: 2 50x115 in Oslo 09-C (stitching Red), Madrid 04-C (stitching Red); 1 65x50 in Madrid 05-C (stitching Grigio Scuro).

↑ Inout 701: Poltrona/ armchair. Seduta/seat in Oslo 09-C (stitching Red). Cuscini/ cushions: 2 50x115 in Oslo 09-C (stitching Red), Madrid 05-C (stitching Grigio Scuro); 1 65x50 in Oslo 06-C (stitching Red).

↑ Inout 703: Divano/ sofa. Seduta/seat in Oslo 09-C (stitching Red). Cuscini/ cushions: 5 50x115 in Madrid 04-C (stitching Red), Madrid 05-C (stitching Grigio Scuro), Oslo 09-C (stitching Red); 2 65x50 in Oslo 06-C (stitching Red).



Inout 742, 744

Inout 709



Inout 707

Inout 48

← Inout 709: Dondolo/ Rocking chair. Seduta/seat in Madrid 06-C (stitching Blu Scuro). Cuscini/ cushions: 1 65x80 in Aspen 02-C (stitching Blu Scuro), 1 65x50 in Dublin 07-C (stitching Blu Scuro).

← Inout 709: Dondolo/ Rocking chair. Seduta/seat in Berlin 03-C (stitching Blu Scuro). Cuscini/ cushions: 1 65x80 in Berlin 03-C (stitching Blu Scuro), 1 65x50 in Aspen 02-C (stitching Blu Scuro).

↑ Inout 707: Poltrona/ Armchair. Seduta/seat in Berlin 02-C (stitching Blu Scuro). Cuscini/ cushions: 2 65x50 in Dublin 06-C (stitching Blu Scuro), Aspen 02-C (stitching Blu Scuro), 1 50x50 in Dublin 07-C (stitching Blu Scuro).

Materials, Colors, Drawings →

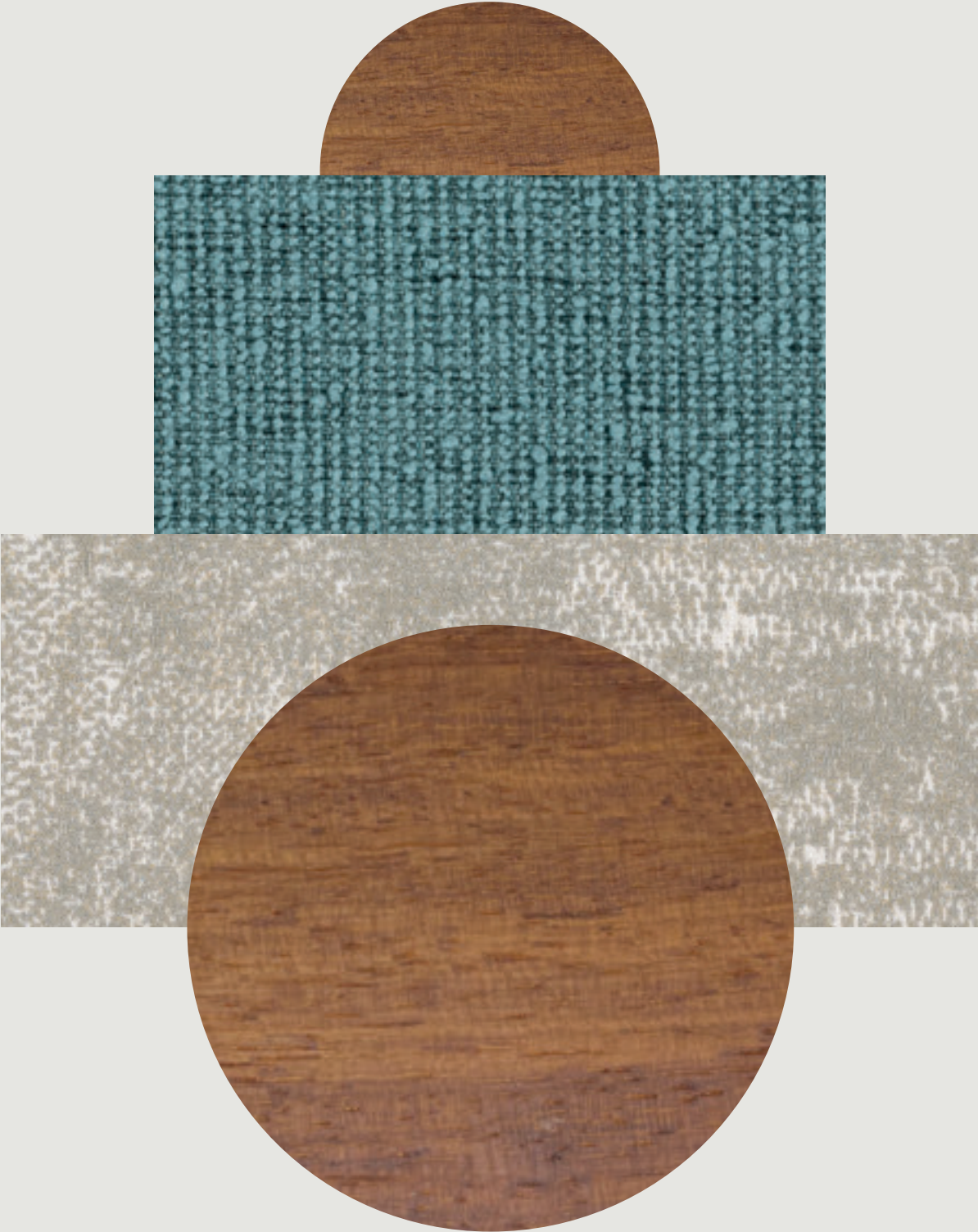

Iroko

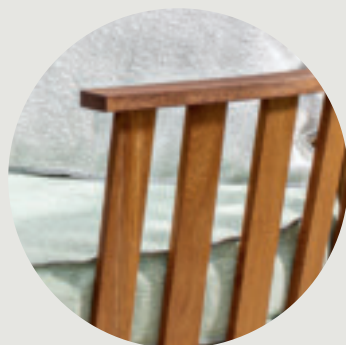

Il legno Iroko è una specie particolarmente dura proveniente dalle foreste dei paesi dell'Africa equatoriale. Essendo un legno resinoso è per natura protetto dall'acqua e dall'umidità. Ha notevoli qualità meccaniche, come la particolare resistenza alla flessione. L'Iroko utilizzato nella collezione è legno massello stabilizzato in forni di essiccazione e successivamente oliato, procedimenti che, oltre ad aumentarne la compattezza, ne esaltano anche le venature o sfumature di colore.

L'Iroko est une espèce particulièrement dure provenant des forêts d'Afrique équatoriale. En tant que résineux, il est naturellement protégé de l'eau et de l'humidité. Il possède de remarquables propriétés mécaniques, comme sa résistance particulière à la flexion. L'Iroko utilisé dans cette collection est un bois massif séché au four et après huilé, ce qui non seulement augmente sa compacité, mais exalte également ses veines ou ses nuances de couleur.

Iroko wood is a particularly hard species from the forests of tropical Africa. Being a resinous wood, it is naturally protected against water and moisture. It features impressive mechanical qualities, such as resistance to bending. The Iroko used in the collection is a solid wood stabilised in drying ovens and oiled afterwards, procedures which not only improve its compactness but also highlights grains and shades of colour.

Iroko ist ein besonders hartes Holz aus den Wäldern Äquatorialafrikas. Da es sich um ein harzreiches Holz handelt ist es von Natur aus wasser- und feuchtigkeitsfest. Es besitzt außergewöhnliche mechanische Eigenschaften, darunter die besondere Festigkeit. Bei dem für diese Kollektion verwendete Iroko, handelt es sich um ein Massivholz, das in Trockenöfen stabilisiert und danach geölt wird, was ihm nicht nur mehr Dichte verleiht, sondern auch seine Maserung und die Farbnuancen hervorhebt.

Upholstery



L'imbottitura dei cuscini di seduta e schienale è realizzata in poliuretano espanso per renderla più compatta e resistente. La perfetta impermeabilizzazione delle imbottiture è garantita dal rivestimento con fodere in poliestere, trattate con specifici prodotti idrofughi e idrorepellenti, e dalle cuciture termosaldate. Tutti i cuscini e le parti imbottite in collezione sono sfoderabili.

Le garnissage des assises et des dossiers est réalisé en polyuréthane expansé afin de les rendre plus compacts et résistants. Il est parfaitement imperméabilisé grâce à des housses en polyester aux propriétés hydrofuges et hydrophobes et grâce aux coutures thermosoudées. Tous les coussins et les parties rembourrées de la collection sont déhoussables.

The padding of the seat and back cushions is made of polyurethane foam to improve their compactness and resilience. The perfect water-repellence is guaranteed by the polyester cushion covers, treated with specific waterproof and water-repellent products, and the heat welded seams. All the cushions and upholstered elements of the collection have removable covers.

Die Polsterung der Sitze und Rückenlehnen wird aus Polyurethanschaum hergestellt, wodurch sie besonders kompakt und widerstandsfähig sind. Die perfekte Abdichtung der Polsterung wird durch die Polyester Überzüge garantiert, die mit speziellen wasserabweisenden Produkten behandelt und mit Thermobandierung versehen sind. Sämtliche Kissen und Polster Elemente der Kollektion sind abziehbar.

Inout 701
p. 172-173, 176-177

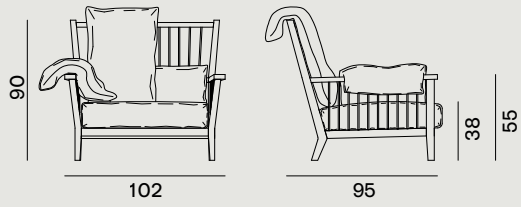

1 2
65x50 50x115

Inout 703
p. 168, 172-173, 177



2 5
65x50 50x115

Inout 707
p. 174, 175, 179, 183

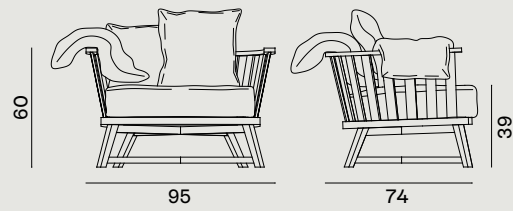

1 2
50x50 65x50

Inout 709
p. 171, 172-173, 178

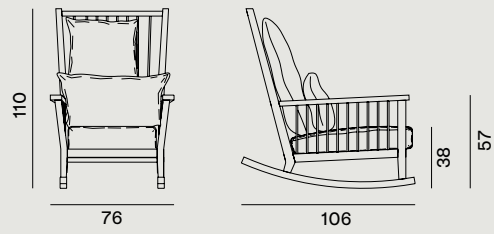

1 1
65x50 65x80

Inout 742
p. 176, 177, 178

Tech. Spec. → p. 294

Inout 744
p. 177, 178

Tech. Spec. → p. 294

C. Inout 7S

C. Inout 7PI

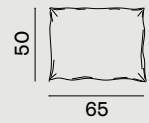
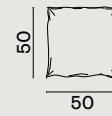
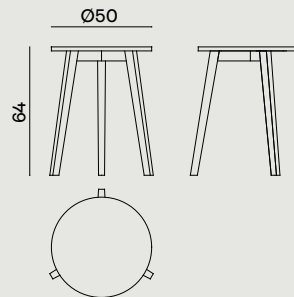
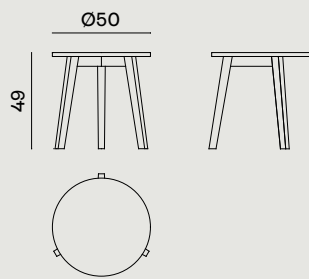

C. Inout 7GR

C. Inout 7XL

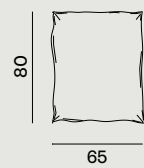





Ghost Out Collection

Design by
Paola Navone

185

Ghost Out Collection

IT. Per impreziosire l'outdoor con il comfort speciale di divani e poltrone, la collezione è stata progettata con caratteristiche tecniche ad hoc per resistere all'acqua, e alla luce solare, e per mantenere inalterate nel tempo la loro forma e la loro bellezza.



EN.

To enhance your outdoor setting with the exclusive comfort of sofas and armchairs, the collection has been designed with ad hoc technical characteristics to resist against water and sunlight, maintaining their shape and beauty unaltered over time.

FR.

Pour enrichir son extérieur avec des canapés et des fauteuils confortables, cette collection a été conçue sur la base de caractéristiques techniques ad hoc pour résister à l'eau et à la lumière du soleil et conserver au fil du temps leur forme et leur beauté.

DE.

Die Kollektion wurde mit speziellen technischen Merkmalen ausgestattet, um auch im Außenbereich den besonderen Komfort von Sofas und Sesseln genießen zu können. Polsterung und Stoffe wurden entwickelt, um sowohl gegenüber Wasser wie Sonnenlicht beständig zu sein und so ihre Form und Schönheit über lange Zeit zu bewahren.





Brise 44

Inout 44

Inout 47

Ghost Out 16

Inout 49

Inout 42

Rug Guna 02 Natural



← Ghost Out 16: Divano/
Sofa in Lisboa 02-C.
Cuscini/ Cushions: 3 80x80
in Lisboa 02-C; 2 120x30
in Lisboa 02-C; 4 60x60 in
Lisboa 07-C, Lisboa 05-C,
Aspen 04-C; 4 50x50 in
Madrid 02-C, Madrid 03-C.

← Hashi 09: Dondolo/
Rocking chair.
→ Loose cushion: 1 C. Hashi XS
in in Odessa 01-C.
← Rug Guna 02 Natural:
Tappeto/ Carpet.

→ Ghost Out 12: Divano/
Sofa in Dublin 01-C.
Cuscini/ Cushions: 4 60x60
in Aspen 04-C, Dublin 01-C;
2 50x50 in Capri 01-C.
→ Rug Eco 02 Natural:
Tappeto/ Carpet.

→ Ghost Out 05: Poltrona/
Armchair in Aspen 04-C.
Cuscini/ Cushions: 1 50x50
in Capri 01-C.
→ Ghost Out 05: Poltrona/
Armchair in Aspen 04-C.
Cuscini/ Cushions: 1 50x50
in Dublin 05-C.





Jeko 41

Ghost Out 05

Jeko 46

Rug Eco 02 Natural





← Ghost Out 09: Poltrona/
Armchair in Lisboa 05-C.
Cuscini/ cushions: 2 60x60 in
Oslo 09-C, Lisboa 06-C.
← Rug Eco 02 Natural:
Tappeto/ Carpet.

→ Ghost Out 12: Divano/
Sofa in London 07-C.
Cuscini/ cushions: 4 60x60
in Lisboa 01-C, Lisboa 05-C;
2 50x50 in Lisboa 07-C,
Lisboa 01-C.

→ Ghost Out 09: Poltrona/
Armchair in Lisboa 05-C.
Cuscini/ cushions: 2 60x60
in Aspen 04-C.





Ghost Out 12

Ghost Out 09



Inout 847

Ghost Out 25



←↑ Ghost Out 25: Poltroncina/
Armchair in Lisboa 07-C.

←↑ Inout 847: Tavolo quadrato.
Base in alluminio slate, piano in
marmo bianco Carrara./ Square
table. Slate aluminum central
base, white Carrara marble top.

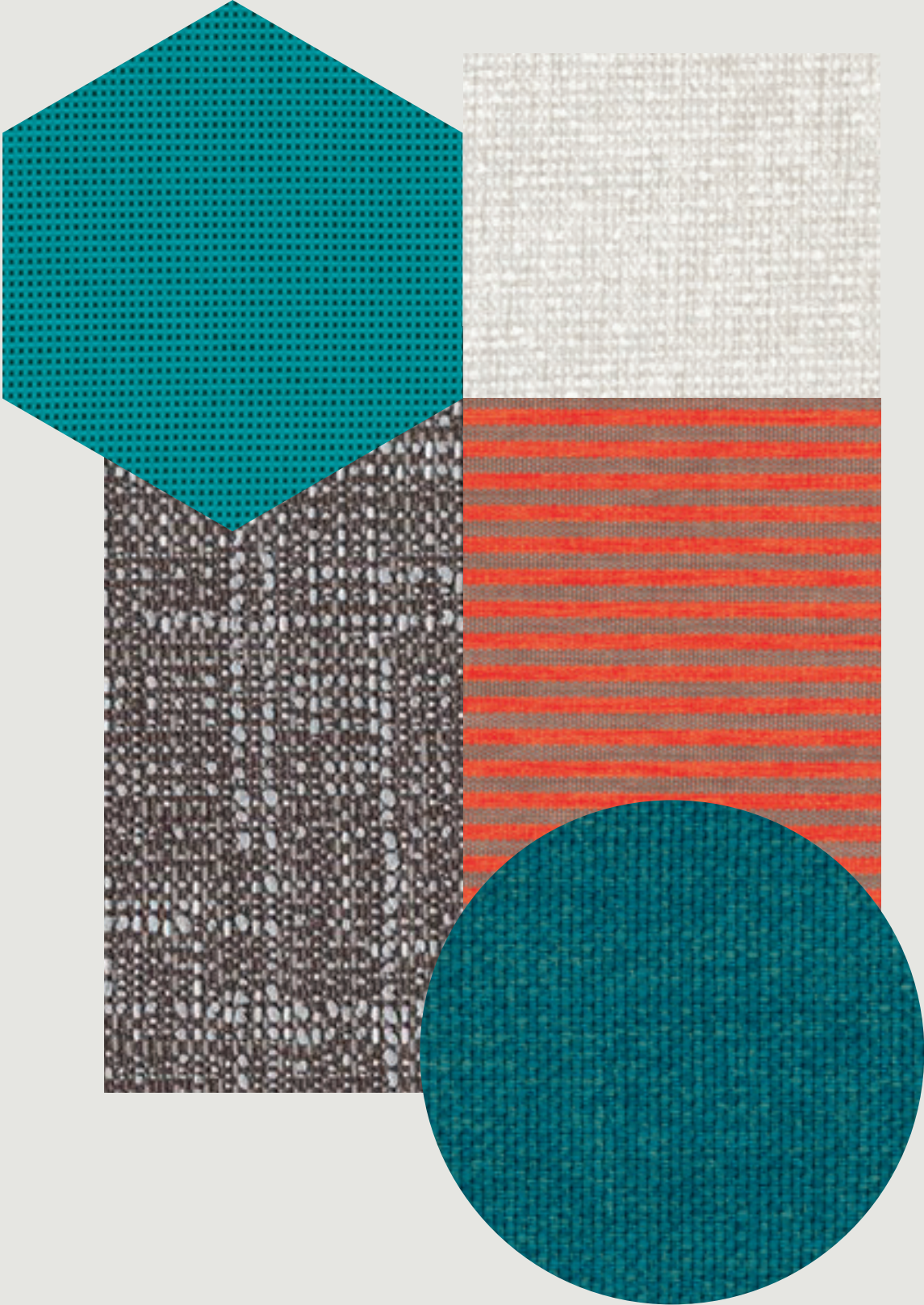

Upholstery



Braccioli e schienale sono separati dalla seduta per permettere il deflusso dell'acqua. Le imbottiture e i tessuti di rivestimento sono stati appositamente sviluppati per resistere all'acqua e alla luce solare. La perfetta impermeabilizzazione delle imbottiture in poliuretano espanso è garantita dal rivestimento con fodere in poliestere, trattate con specifici prodotti idrofughi e idrorepellenti, e dalle cuciture termonastrate.

Les accoudoirs et le dossier sont séparés de l'assise pour permettre à l'eau de s'écouler et éviter ainsi une stagnation de l'humidité. De même, le garnissage et les tissus de revêtement ont été spécialement développés pour résister à l'eau et à la lumière du soleil. Le garnissage en polyuréthane expansé est parfaitement imperméabilisé grâce à des housses en polyester aux propriétés hydrofuges et hydrophobes et grâce aux coutures thermosoudées.

Armrests and backs are separated from the seat to allow the water to drain and avoid the build-up of moisture. Likewise, the padding and upholstery fabrics have been specifically developed to resist against water and sunlight. The perfect water-repellence of the polyurethane foam padding is guaranteed by the polyester cushion covers, treated with specific waterproof and water-repellent products, and the heat welded seams.

Die Arm- und Rückenlehnen sind nicht mit der Sitzfläche verbunden, damit das Wasser abfließen kann und sich keine Feuchtigkeit ansammelt. Auch die Polsterung und die Stoffe wurden entwickelt, um sowohl gegenüber Wasser wie Sonnenlicht beständig zu sein. Die vollkommene Impermeabilisierung der Füllungen aus geschäumten Polyurethan wird durch die Polyester-Bezüge, die mit speziellen wasserabweisenden Produkten behandelt wurden, und die Thermobandierung gewährleistet.

Ghost Out 05
p. 191

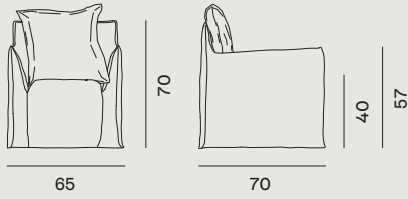

1
50x50

Ghost Out 09
p. 192, 194-195

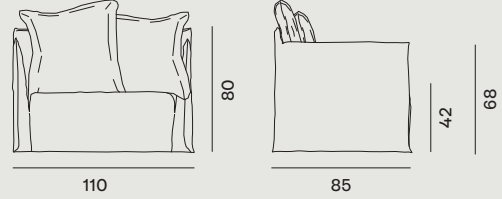

2
60x60

Ghost Out 10

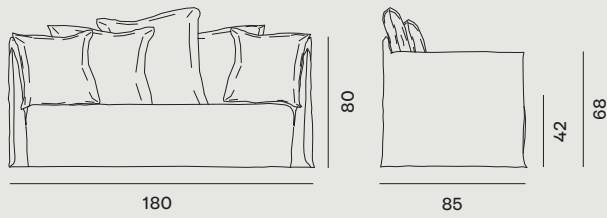

2 3
50x50 60x60

Ghost Out 12
p. 190-191, 194-195

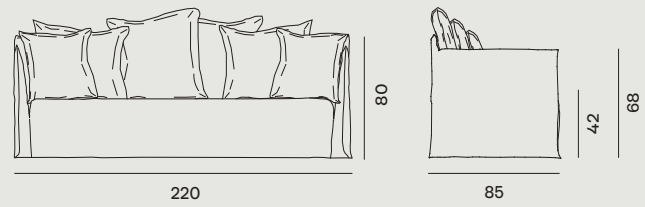

2 4
50x50 60x60

Ghost Out 16
p. 187, 188-189

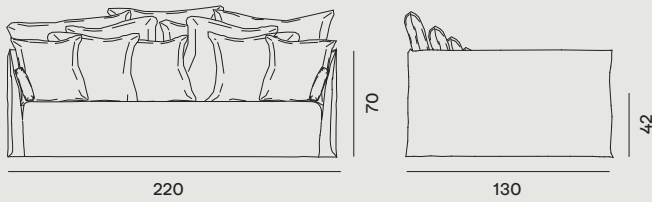

4 4 3 2
50x50 60x60 80x80 120x30

Ghost Out 23 Tech. Spec. → p. 266
p. 032, 060-061, 092-093, 126-127

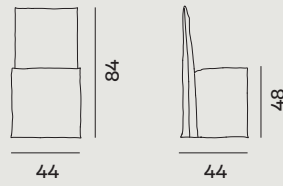

Ghost Out 25 Tech. Spec. → p. 266
p. 196, 197

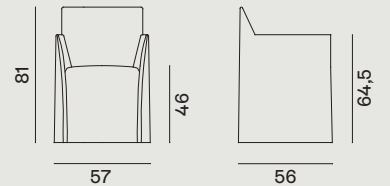

C. Ghost Out XS

C. Ghost Out PI

C. Ghost Out GR

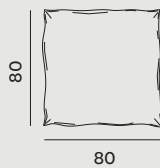
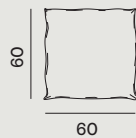
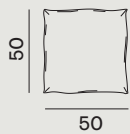





Panda Collection

Design by
Paola Navone

203

Panda Collection

IT. Forme morbide ed extra comfort per le poltrone e i divani della collezione Panda, realizzati con struttura in alluminio, intreccio in fibra sintetica di polietilene e morbidi cuscini oversize. La tradizione dell'intreccio viene reinterpretata da Gervasoni per l'outdoor con l'utilizzo di fibre sintetiche di ultima generazione, sviluppate per resistere all'acqua e alla luce.



EN.

Soft shapes and extra comfort for the armchairs and sofas in the Panda collection, made with an aluminium frame with weave in polyethylene synthetic fibre and soft oversize cushions. The weaving tradition is reinterpreted by Gervasoni for outdoor furniture using latest generation synthetic fibres, designed to perfectly resist against water and sunlight.

FR.

Souplesse et ultra confort pour les fauteuils et canapés de la collection Panda, réalisés à partir d'une structure en aluminium, d'un tressage en fibres synthétiques de polyéthylène et de coussins oversize des plus moelleux. Gervasoni réinterprète la tradition du tressage et l'adapte à l'outdoor en utilisant des fibres synthétiques de dernière génération, conçues pour résister à l'eau et à la lumière.

DE.

Weiche Formen und ein besonderer Komfort zeichnen die Sessel und Sofas der Kollektion Panda mit Aluminiumgestell, Geflecht aus Polyethylenfasern und weichen Oversize-Kissen aus. Die traditionelle Flechtkunst wird von Gervasoni für den Außenbereich unter Verwendung von Kunstfasern der neuesten Generation neu interpretiert, die eigens entwickelt wurden, um sowohl gegenüber Wasser wie Licht beständig zu sein.



Inout 44

Panda 05

Inout 47

↑ Panda 05: Poltrona/ Armchair.
Seduta/ Seat in London 02-C.
Cuscini/ Cushions: 170x70 in
London 07-C (stitching Grigio
Scuro); 1 50x50 in Aspen 04-C
(stitching Grigio Scuro).



Panda 13

Panda 11

Panda 04

Inout 47



Panda 05

Inout 44

← Panda 04: Divano/ Sofa.
Seduta/ Seat in London 02-C.
Cuscini/ Cushions: 2 90x90 in
London 07-C (stitching Grigio
Scuro), Aspen 04-C (stitching
Grigio Scuro); 3 50x50 in Oslo
04-C (stitching Grigio Scuro),
Aspen 04-C (stitching Grigio
Scuro), Oslo 09-C (stitching
Grigio Scuro).

← Rug Guna 02 Blue:
Tappeto/ Carpet.

← Rug Guna 01 Blue:
Tappeto/ Carpet.



Panda 13

Inout 43

Panda 04



← Panda 04: Divano/ Sofa.
Seduta/ Seat in Oslo 01-C.
Cuscini/ Cushions: 2 90x90 in
Oslo 04-C; 3 50x50 in Capri
03-C, Capri 06-C.

↑ Panda 01: Poltrona/ Armchair.
Seduta/ Seat in Capri 04-C.
Cuscini/ Cushions: 1 90x90 in
Capri 03-C; 1 70x70 in Capri
06-C; 1 50x50 in Capri 01-C.



Inout 42, 43

Panda 05



Panda 01

↑ Panda 05: Poltrona/ Armchair.
 Seduta/ Seat in Capri 04-C.
 Cuscini/ cushions: 170x70
 Capri 03-C; 1 50x50 in Capri
 06-C.



Random 96

Panda 13

Panda 03

Inout 44

Panda 11

↑ Panda 01: Poltrona/ Armchair.
Seduta/ Seat in Capri 04-C.
Cuscini/ Cushions: 190x90 in
Capri 03-C; 170x70 in Capri
06-C; 150x50 in Capri 01-C.

↑ Panda 03: Divano/ Sofa.
Seduta/ Seat in Capri 06-C.
Cuscini/ cushions: 290x90 in
Capri 01-C; 270x70 in Capri
04-C; 350x50 in Capri 07-C,
Capri 06-C.



Inout 48

Panda 19

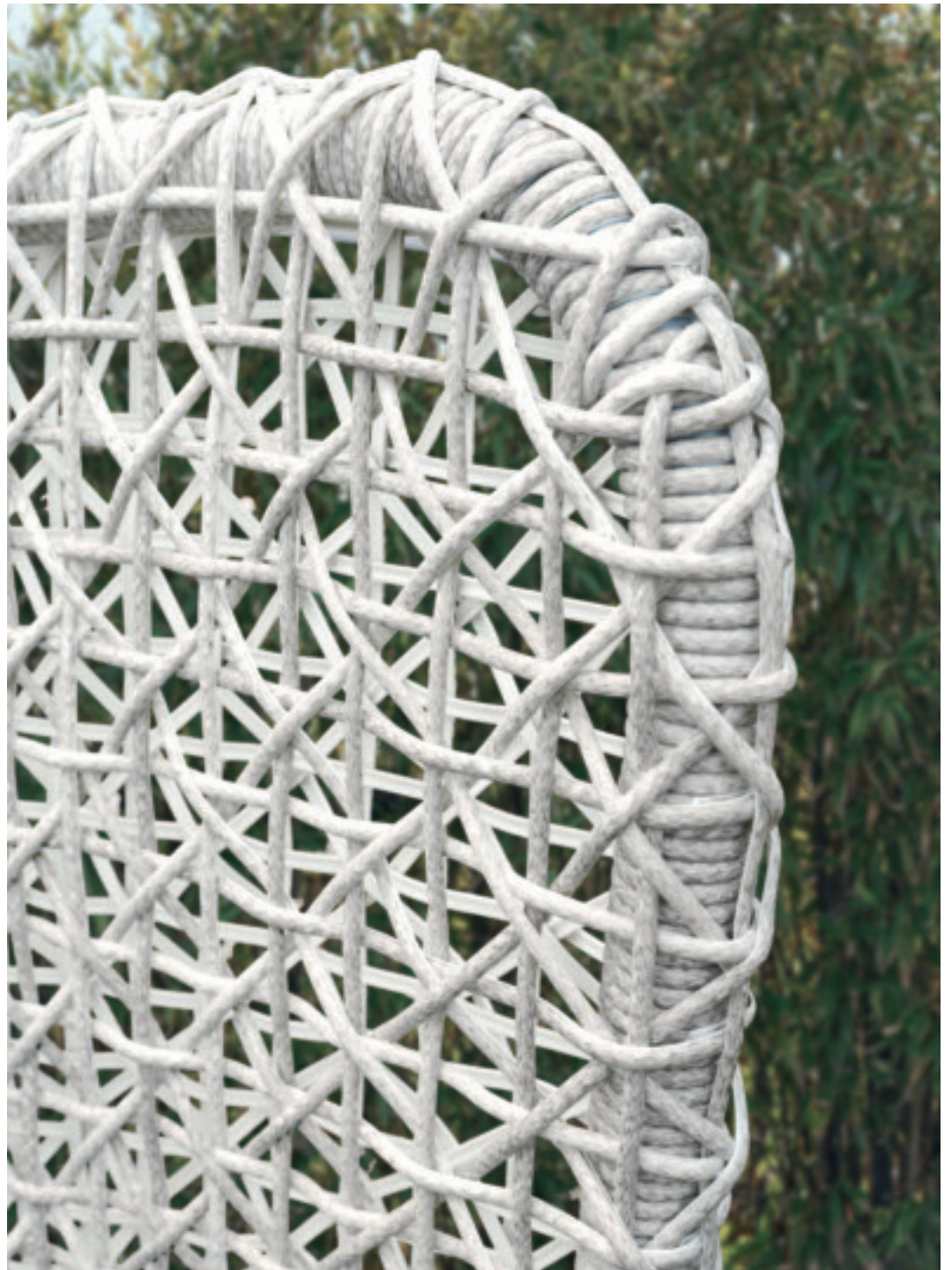

← Panda 19: Poltrona/ Armchair.
Seduta/ Seat in Dublin 02-C.
Cuscino/ cushion: 1 50x50
Capri 01-C.

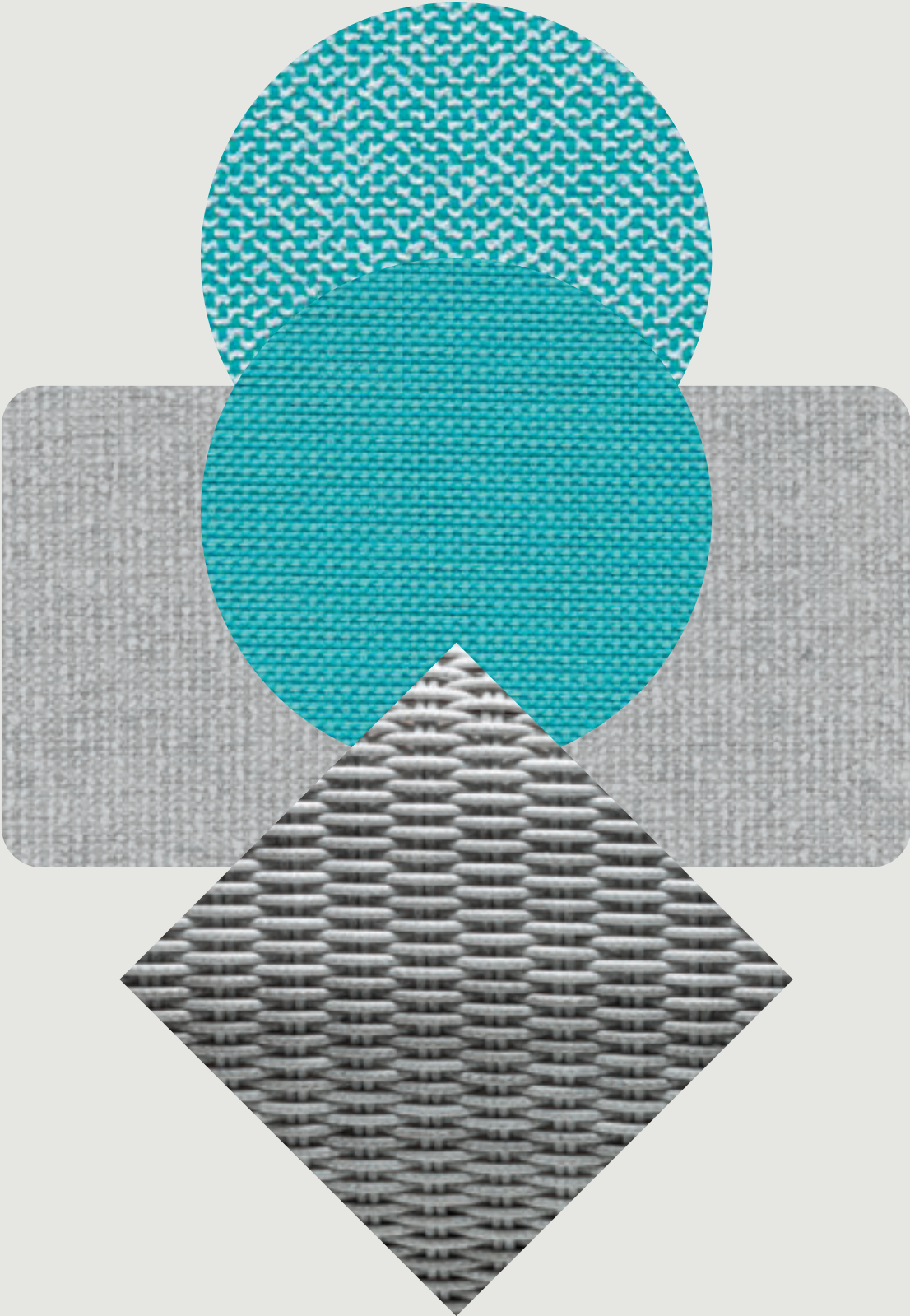

Panda Resin

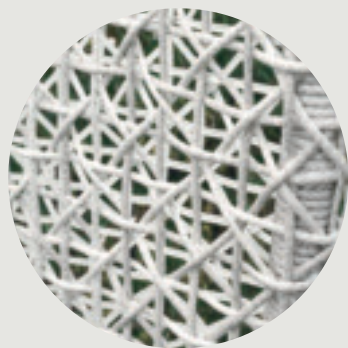

L'intreccio della collezione è realizzato con una fettuccia estrusa (Panda resin) in polietilene. Appositamente progettata per l'outdoor, è una fibra dall'aspetto naturale, forte, flessibile e durevole, conforme agli standard più severi in termini di resistenza alle radiazioni solari, all'umidità e all'acqua (anche acqua di mare e acqua clorata). Panda resin è realizzata con polietilene di alta qualità e coloranti inorganici ed ecologici, in conformità alla normativa internazionale REACH in tema di gestione dei rischi delle sostanze chimiche. La qualità ecologica del materiale e dei processi produttivi è convalidata dalla certificazione STANDARD 100 by OEKO-TEX®. Panda resin è 100% riciclabile.

The weave used in the collection is developed with extruded polyethylene fiber (Panda resin). Specifically designed for outdoor furniture, the fibre is characterised by its natural appearance, strength, flexibility and durability and satisfies the strictest standards in terms of resistance to solar radiation, moisture and water (including sea water and chlorinated water). Panda resin is made with high quality polyethylene and inorganic, ecological dyes in compliance with the international REACH standard concerning the management of risks linked to chemical substances. The ecological quality of the material and the manufacturing processes is validated by OEKO-TEX® STANDARD 100 certification. Panda resin is 100% recyclable.

Le tressage de cette collection est réalisé à l'aide d'un ruban extrudé (Panda resin) en fibre synthétique. Spécifiquement conçue pour l'extérieur, il s'agit d'une fibre d'aspect naturel, solide, flexible et durable, conforme aux standards les plus exigeants en termes de résistance aux rayonnements solaires, à l'humidité et à l'eau (y compris à l'eau de mer et à l'eau chlorée). Cette fibre est réalisée à base de polyéthylène haute qualité et de colorants inorganiques et écologiques, conformément à la réglementation internationale REACH en matière de gestion des risques liés aux substances chimiques. La qualité écologique des produits et des procédés de fabrication est garantie par la certification STANDARD 100 by OEKO-TEX®. Elle est 100 % recyclable.

Das Flechtwerk der Kollektion wird aus extrudierten Bändern (Panda resin) aus Polyethylen hergestellt, das speziell für den Outdoor-Gebrauch entwickelt wurde. Es handelt sich um eine natürlich wirkende, starke, flexible und langlebige Faser, die den strengsten Standards hinsichtlich der Widerstandsfähigkeit gegenüber Sonnenstrahlen, Feuchtigkeit und Wasser (einschließlich Meerwasser und gechlortem Wasser) entspricht. Panda resin wird aus Polyethylen bester Qualität mit anorganischen, ökologischen Farbstoffen hergestellt, gemäß der internationalen REACH-Norm zum Umgang mit chemischen Stoffen. Die umweltfreundliche Qualität der Produkte und der Produktionsprozesse wird durch die Zertifizierung STANDARD 100 by OEKO-TEX® garantiert. Panda resin ist 100 % recycelbar.

Upholstery



L'imbottitura dei cuscini di seduta e schienale è realizzata in poliuretano espanso per renderla più compatta e resistente. La perfetta impermeabilizzazione delle imbottiture è garantita dal rivestimento con fodere in poliestere, trattate con specifici prodotti idrorepellenti e idrorepellenti, e dalle cuciture termosaldate. Tutti i cuscini e le parti imbottite in collezione sono sfoderabili.

The padding of the seat and back cushions is made of polyurethane foam to improve their compactness and resilience. The perfect water-repellence is guaranteed by the polyester cushion covers, treated with specific waterproof and water-repellent products, and the heat welded seams. All the cushions and upholstered elements of the collection have removable covers.

Le garnissage des assises et des dossiers est réalisé en polyuréthane expansé afin de les rendre plus compacts et résistants. Il est parfaitement imperméabilisé grâce à des housses en polyester aux propriétés hydrofuges et hydrophobes et grâce aux coutures thermosoudées. Tous les coussins et les parties rembourrées de la collection sont déhoussables.

Die Polsterung der Sitze und Rückenlehnen wird aus Polyurethanschäum hergestellt, wodurch sie besonders kompakt und widerstandsfähig sind. Die perfekte Abdichtung der Polsterung wird durch die Polyester Überzüge garantiert, die mit speziellen wasserabweisenden Produkten behandelt und mit Thermobandierung versehen sind. Sämtliche Kissen und Polster Elemente der Kollektion sind abziehbar.

Panda 01
p. 209, 211

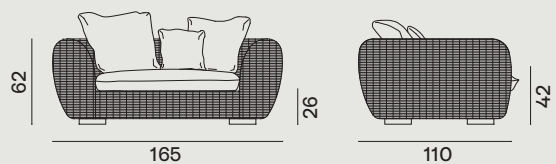

Panda 02

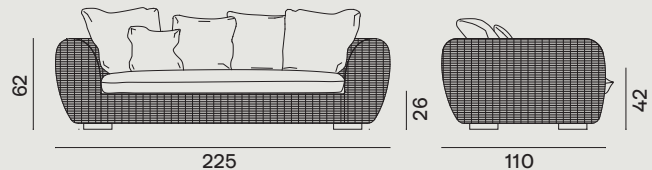

Panda 03
p. 211

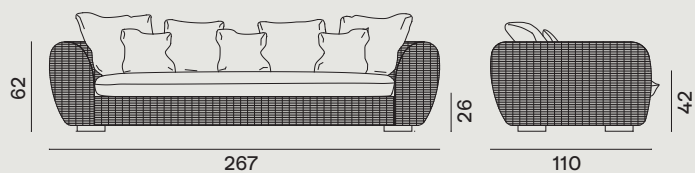

Panda 04
p. 206-207, 208

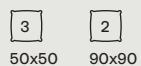
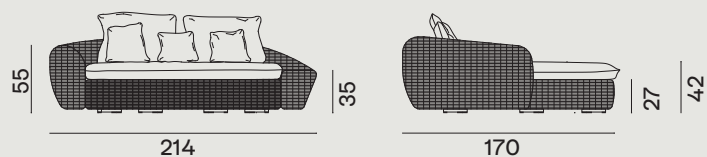

Panda 05
p. 205, 206-207, 210, 217

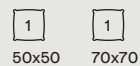
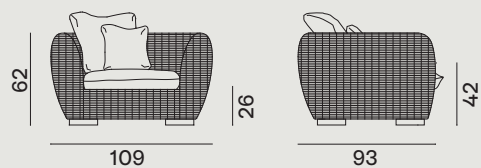

Panda 11
p. 206-207, 211

Tech. Spec. → p. 296

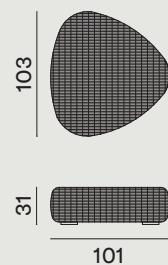

Panda 13
p. 202, 206, 208

Tech. Spec. → p. 296

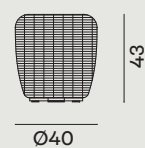

Panda 19
p. 209, 212, 213

C. Panda S

C. Panda M

C. Panda L

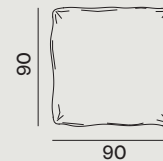
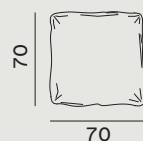
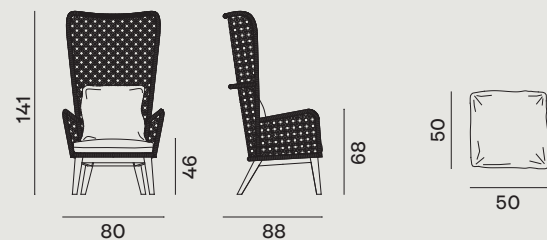





Straw Collection

Design by
Paola Navone

219

Straw Collection

IT. Sofisticata, resistente e leggera, le sedute della collezione sono caratterizzate da struttura in tubolare di alluminio verniciato e da un particolare intreccio a tripla corda di polietilene dal colore naturale.



EN.

Sophisticated, resilient and lightweight, the seats in the collection are characterised by a painted tubular aluminium frame and a special weave with a three-strand natural coloured rope in polyethylene.

FR.

Sophistiqués, résistants et légers, les sièges de cette collection se caractérisent par une structure en tube d'aluminium verni et par une triple corde en polyéthylène tressée de couleur naturelle.

DE.

Die raffinierten, robusten und leichten Sitzflächen dieser Kollektion zeichnen sich durch das lackierte Gestell aus Aluminiumrohr und ein besonderes Geflecht aus naturfarbenem dreifachem Polyethyleneseil aus.



Straw 23

Inout 33

Straw 24

↑ Inout 33: Tavolo rettangolare. Gambe in cemento GFRC blu, piano a doghe di teak naturale./ Rectangular table. Blue GFRC concrete legs, natural teak slats top.



Straw 23

Inout 836

Straw 24



← Inout 836: Tavolo rotondo.
Base centrale in cemento. Piano
in marmo bianco Carrara./ Round
table. Central concrete base.
White Carrara marble top.



→ Inout 137: Tavolo quadrato.
Base in pietra Piasentina, colonna
centrale in alluminio Agate,
piano a doghe in teak naturale.
/ Square table. Piasentina stone
base, Agate aluminium central
column, natural teak slats top.



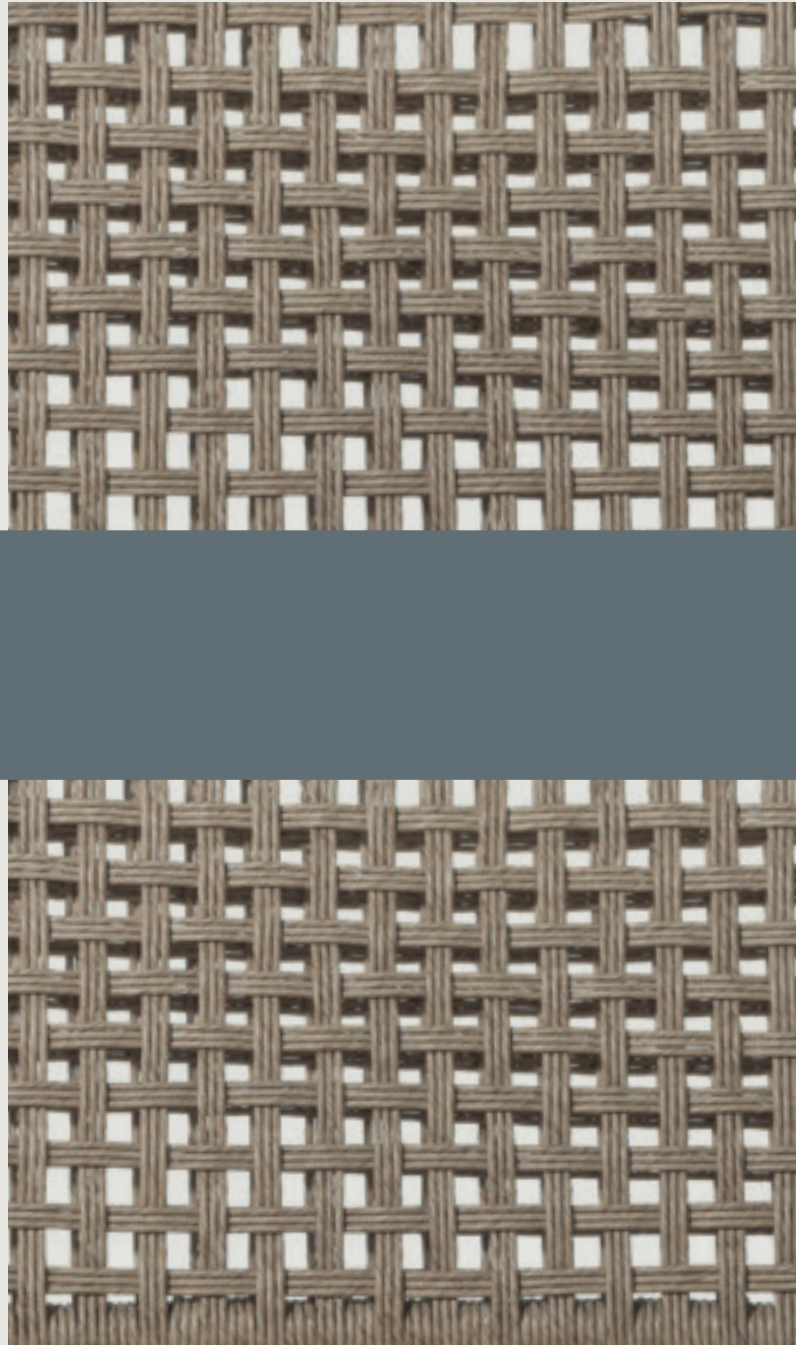

Straw Resin



L'intreccio della collezione è realizzato con una corda in polietilene a doppia torsione (Straw resin). Appositamente progettata per l'outdoor, è una fibra dall'aspetto naturale, forte, flessibile e durevole, conforme agli standard più severi in termini di resistenza alle radiazioni solari, all'umidità e all'acqua (anche acqua di mare e acqua clorata). Straw resin è realizzata con polietilene ad alta densità e coloranti inorganici ed ecologici, in conformità alla normativa internazionale REACH in tema di gestione dei rischi delle sostanze chimiche. La qualità ecologica del materiale e dei processi produttivi è convalidata dalla certificazione STANDARD 100 by OEKO-TEX®. Straw resin è 100% riciclabile.

Le tressage de cette collection est réalisé à l'aide d'une corde à double torsion (Straw resin) en fibre synthétique. Spécifiquement conçue pour l'extérieur, il s'agit d'une fibre d'aspect naturel, solide, flexible et durable, conforme aux standards les plus exigeants en termes de résistance aux rayonnements solaires, à l'humidité et à l'eau (y compris à l'eau de mer et à l'eau chlorée). Cette fibre est réalisée à base de polyéthylène haute densité et de colorants inorganiques et écologiques, conformément à la réglementation internationale REACH en matière de gestion des risques liés aux substances chimiques. La qualité écologique des produits et des procédés de fabrication est garantie par la certification STANDARD 100 by OEKO-TEX®. Elle est 100 % recyclable.

The weave of this collection is developed using a double twist rope (Straw resin) in polyethylene. Specifically designed for outdoor furniture, the fiber is characterised by its natural appearance, strength, flexibility and durability and satisfies the strictest standards in terms of solar radiation-resistance, moisture and water (including sea water and chlorinated water). Straw resin is made with high-density polyethylene and inorganic, ecological dyes in compliance with the international REACH standard concerning the management of risks linked to chemical substances. The ecological quality of this material and of the manufacturing process is validated by OEKO-TEX® STANDARD 100 certification. Straw resin is 100% recyclable.

Das Flechtwerk der Kollektion wird aus einem doppelt gedrehten Seil (Straw resin) aus Polyethylen, das speziell für den Outdoor- Gebrauch entwickelt wurde, hergestellt. Es handelt sich um eine natürlich wirkende, starke, flexible und langlebige Faser, die den strengsten Standards hinsichtlich der Widerstandsfähigkeit gegenüber Sonnenstrahlen, Feuchtigkeit und Wasser (einschließlich Meerwasser und gechlortem Wasser) entspricht. Straw resin wird aus Polyethylen bester Qualität mit anorganischen, ökologischen Farbstoffen hergestellt, gemäß der internationalen REACH-Norm zum Umgang mit chemischen Stoffen. Die umweltfreundliche Qualität der Produkte und der Produktionsprozesse wird durch die Zertifizierung STANDARD 100 by OEKO-TEX® garantiert. Straw resin ist 100 % recycelbar.

Slate Aluminium



Oltre che espressivo ed ecologico, l'alluminio è un metallo unico per qualità tecniche. Tre volte più leggero dell'acciaio, è stabile nel tempo, resistente agli agenti atmosferici e di facile manutenzione. In più è riciclabile e può essere riutilizzato all'infinito, senza la minima alterazione delle sue proprietà tecniche e meccaniche. L'alluminio utilizzato nella collezione è oggetto di uno specifico pre-trattamento antisalino che inibisce il naturale processo di ossidazione. Il successivo procedimento di verniciatura a polvere aumenta la resistenza alla corrosione e protegge il metallo anche da graffi e scheggiature.

En plus d'être expressif et écologique, l'aluminium est un métal aux qualités techniques uniques. Trois fois plus léger que l'acier, il est stable dans le temps, résistant aux agents atmosphériques et facile d'entretien. Par ailleurs, il est recyclable et peut être réutilisé indéfiniment, sans la moindre altération de ses propriétés techniques ou mécaniques. L'aluminium employé dans cette collection fait l'objet d'un prétraitement anti-salin qui inhibe le processus naturel d'oxydation. L'étape successive, celle du vernissage en poudre, augmente la résistance à la corrosion et protège également le métal des rayures et des éclats.

In addition to being expressive and ecological, aluminum is also a unique metal in terms of technical qualities. Three times lighter than steel, it offers stability over time, resistance to the weathering and easy maintenance. Moreover, it is recyclable and can be reused an infinite number of times without the slightest alteration of its technical and mechanical properties. The aluminum of the collection has been preprocessed using a specific anti-saline pretreatment, which inhibits the natural oxidation process. The subsequent powder-coating process increases resistance to corrosion while also protecting the metal against scratches and chipping.

Aluminium ist nicht nur ausdrucksvoll und umweltfreundlich, sondern auch einzigartig, was seine technischen Eigenschaften angeht. Es ist dreimal leichter als Stahl, beständig im Laufe der Zeit, widersteht atmosphärischen Einflüssen und ist leicht zu pflegen. Darüber hinaus ist es recycelbar und kann immer weiter verwendet werden, ohne die geringste Beeinträchtigung seiner technischen und mechanischen Eigenschaften. Das für die Kollektion verwendete Aluminium ist Gegenstand einer besonderen Behandlung, die es gegenüber Salz beständig macht und den natürlichen Oxydationsprozess verhindert. Die folgende Pulverbeschichtung erhöht die Korrosionsbeständigkeit und schützt das Metall vor Kratzern und Absplitterungen.

Straw 23
p. 221, 222, 225

Tech. Spec. → p. 272

Straw 24
p. 218, 221, 222, 225

Tech. Spec. → p. 272

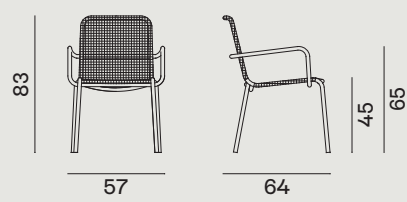
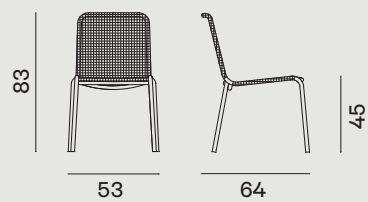





Dining Tables

Inout 33, 34, 35	233
Inout 137	236
Inout 143, 144, 155	240
Inout 834, 836	244
Inout 837, 838	246
Inout 847, 848	248
Jeko 31, 33, 34, 35	252
Kasane 33, 35, 36	256
Brise 33, 34, 38	258

Chairs

Inout 823, 824, 828, 855	263
Ghost Out 23, 25	266
Jeko 24	268
Brise 23, 24	270
Straw 23, 24	272

Complements

Inout 41, 42, 43, 44, 91, 92	277
Inout 47, 48, 49	280
Heiko 41, 42, 43, 44	282
Guna 11, 12	284
Brise 43, 44, 46	286
Brise 53, 54, 56	288
Jeko 11, 14	290
Jeko 40, 41, 46	291
Inout 742, 744	294
Panda 11, 13	296
Guna Rugs	298
Eco Rugs	302
Random 96	304

Dining Tables, Chairs, Complements

Dining Tables

IT. Il piacere del convivio all'aria aperta declinato in tante forme diverse. La mescolanza di materiali non convenzionali per l'outdoor eppure perfettamente idonei – come ceramica, marmo, cemento, alluminio o acciaio – suggerisce nuovi modi di pensare la tavola all'aperto, che sia per tanti ospiti o per pochi intimi.

EN.

The joy of outdoor entertaining articulated into lots of different forms. The mix of non-conventional, yet perfectly suitable outdoor materials - such as ceramics, marble, cement, aluminium or steel - suggests new ways of conceiving the outdoor table whether for large groups or close relatives and friends.

FR.

Le plaisir de recevoir dehors décliné sous de nombreuses formes différentes. Le mélange de matériaux non conventionnels et pourtant tout à fait adaptés à un usage extérieur – comme la céramique, le marbre, le béton, l'aluminium ou l'acier – suggère de nouvelles façons de penser la table d'extérieur, que ce soit pour un grand nombre d'invités ou pour un petit comité.

DE.

Die ganze Vielfalt des Vergnügens, im Freien zu speisen. Die Mischung von Materialien – wie Keramik, Marmor, Beton, Aluminium oder Stahl, die in Außenbereichen eher ungewöhnlich, aber bestens geeignet sind, regt neue Formen des Essens im Freien an, ob in großer Runde oder im kleinen Kreis.



Inout 33, 34



Inout 33 p. 106-107, 108, 109, 221

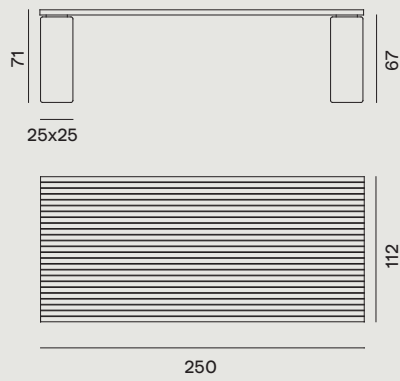

Inout 34

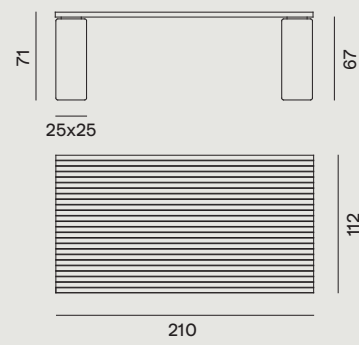

Inout 35

p. 114

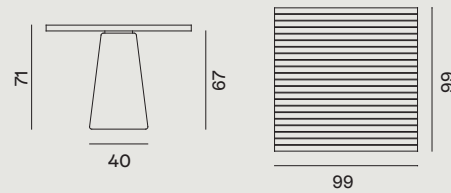

Top finishes

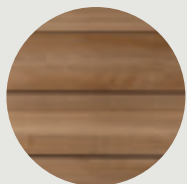

Teak

Legs finishes



GRFC Concrete
White

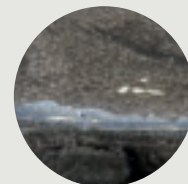

GRFC Concrete
Grey

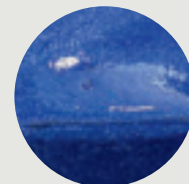

GRFC Concrete
Blue

Teak



Il Teak (*Tectona grandis*) è uno dei più pregiati legni tropicali con eccezionali caratteristiche di durezza, duttilità e resistenza agli agenti atmosferici, all'umidità, alla salsedine. La sua particolarità deriva dalla presenza di una resina oleosa che ne aumenta naturalmente il grado di impermeabilità e di resistenza anche a insetti e parassiti. Il Teak naturale utilizzato per realizzare la collezione proviene da foreste delle regioni tropicali del sud-est asiatico.

Teak (*Tectona grandis*) is one of the most precious tropical woods, having exceptional characteristics of hardness, ductility and resistance to the weathering, moisture and salt. Its uniqueness comes from an oily resin which naturally improves its impermeability and resistance, even to insects and parasites. The natural teak used to develop the collection originates from forests in the tropical regions of Southeast Asia.

Le teck (*Tectona Grandis*) est l'un des bois exotiques les plus prisés. Il possède d'incroyables propriétés de robustesse, de ductilité et de résistance aux agents atmosphériques, à l'humidité et au sel. Sa particularité lui vient de son oléorésine qui augmente naturellement son imperméabilité ainsi que sa résistance aux insectes et parasites. Le teck naturel utilisé pour réaliser cette collection provient de forêts des régions tropicales du sud-est asiatique.

Teak (*Tectona grandis*) ist eines der kostbarsten Tropenholzer und zeichnet sich durch außergewöhnliche Härte, Geschmeidigkeit und Widerstandsfähigkeit gegen atmosphärische Einflüsse, Feuchtigkeit und Salz aus. Seine besonderen Eigenschaften gehen auf ein öliges Harz zurück, das für seine natürliche Impermeabilität und Resistenz gegen Insekten und Parasiten sorgt. Das für die Kollektion verwendete Teak stammt aus Wäldern im tropischen Südostasien.

GRFC Concrete

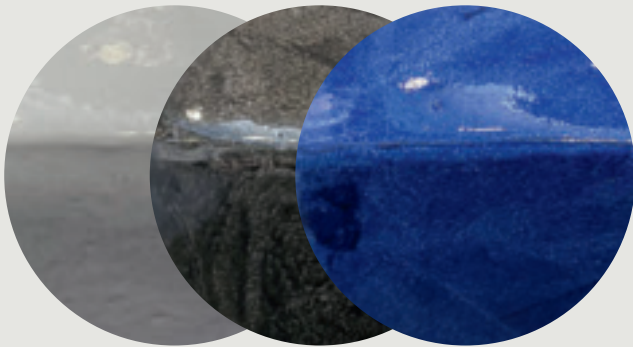

Prodotti realizzati con una miscela di cemento e fibra di vetro verniciati nei colori bianco, nero, blu o grigio antracite con finitura lucida. Il prodotto finale si contraddistingue per una resistenza unica e una maggior durabilità nel tempo.

Products made with a mixture of concrete and glass fiber, white, black, blue or anthracite gray glossy lacquered. The final product stands out for its unique strength and for a greater durability over time.

Les produits sont réalisés avec un mélange de béton et de fibre de verre en blanc, noir, bleu ou gris anthracite, finition brillante. Le produit final se distingue par sa résistance unique et une plus grande durabilité dans le temps.

Die Produkte bestehen aus einer Mischung von Zement und Glasfaser, weiß, schwarz, blau oder anthrazit grau glänzend lackiert. Das Material zeichnet sich durch seine einzigartige Festigkeit sowie eine längere Lebensdauer aus.



Inout 137

p. 111, 224, 225

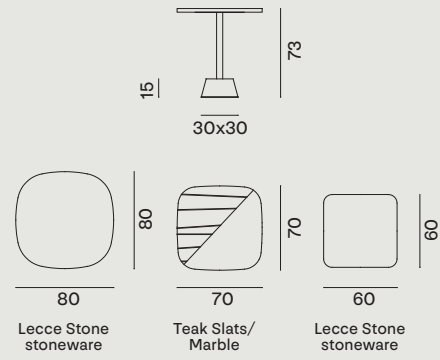

Top finishes



Teak



White Carrara
Marble



Lecce Stone
stoneware

Legs finishes



Aluminium
Pearl

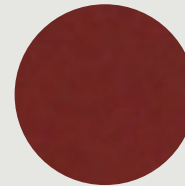

Aluminium
Oxido

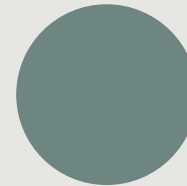

Aluminium
Agate

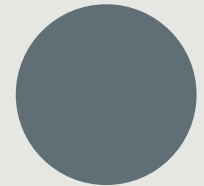

Aluminium
Slate

Teak



Il Teak (*Tectona grandis*) è uno dei più pregiati legni tropicali con eccezionali caratteristiche di durezza, duttilità e resistenza agli agenti atmosferici, all'umidità, alla salsedine. La sua particolarità deriva dalla presenza di una resina oleosa che ne aumenta naturalmente il grado di impermeabilità e di resistenza anche a insetti e parassiti. Il Teak naturale utilizzato per realizzare la collezione proviene da foreste delle regioni tropicali del sud-est asiatico.

Le teck (*Tectona Grandis*) est l'un des bois exotiques les plus prisés. Il possède d'incroyables propriétés de robustesse, de ductilité et de résistance aux agents atmosphériques, à l'humidité et au sel. Sa particularité lui vient de son oléorésine qui augmente naturellement son imperméabilité ainsi que sa résistance aux insectes et parasites. Le teck naturel utilisé pour réaliser cette collection provient de forêts des régions tropicales du sud-est asiatique.

Teak (*Tectona grandis*) is one of the most precious tropical woods, having exceptional characteristics of hardness, ductility and resistance to the weathering, moisture and salt. Its uniqueness comes from an oily resin which naturally improves its impermeability and resistance, even to insects and parasites. The natural teak used to develop the collection originates from forests in the tropical regions of Southeast Asia.

Teak (*Tectona grandis*) ist eines der kostbarsten Tropenholzer und zeichnet sich durch außergewöhnliche Härte, Geschmeidigkeit und Widerstandsfähigkeit gegen atmosphärische Einflüsse, Feuchtigkeit und Salz aus. Seine besonderen Eigenschaften gehen auf ein öliges Harz zurück, das für seine natürliche Impermeabilität und Resistenz gegen Insekten und Parasiten sorgt. Das für die Kollektion verwendete Teak stammt aus Wäldern im tropischen Südostasien.

White Carrara Marble



Alle qualità estetiche, il marmo abbina caratteristiche strutturali, fisiche e morfologiche che lo rendono naturalmente compatto, resistente all'usura e idoneo al contatto con gli alimenti. Il marmo utilizzato in collezione è trattato con impregnante protettivo trasparente opaco.

Le marbre allie à ses qualités esthétiques des propriétés structurelles, physiques et morphologiques qui le rendent naturellement solide, résistant à l'usure et adapté au contact avec les aliments. Le marbre utilisé dans cette collection est protégé à l'aide d'un imprégnant transparent opaque.

The aesthetic qualities of marble are combined with structural, physical and morphological characteristics making it naturally compact, resistant to wear and suitable for contact with food. The marble used in the collection is treated with a clear matt protective impregnating agent.

Neben seinen ästhetischen Qualitäten verbindet der Marmor strukturelle, physische und morphologische Eigenschaften, dank derer er von Natur aus kompakt, widerstandsfähig und für den Kontakt mit Lebensmitteln geeignet ist. Der für die Kollektion verwendete Marmor wird mit einer matt-transparenten Schutzschicht imprägniert.

Lecce Stone stoneware



Ispirato al colore e alla matericità della tradizionale roccia calcarea Salentina, il gres Lecce Stone ha uno spessore di 6 mm ed è caratterizzato da una superficie compatta, refrattaria al calore e particolarmente resistente agli agenti atmosferici, all'umidità e alle muffe. Lavabile con detersivi comuni e facile da mantenere per le qualità antimacchia della superficie, il gres Lecce stone è anche un materiale idoneo al contatto con alimenti.

Le grès Lecce Stone s'inspire à la couleur et la matérialité du calcaire traditionnel du Salento. Le plateau d'une épaisseur de 6 mm présente une surface compacte, réfractaire à la chaleur et particulièrement résistante aux agents atmosphériques, à l'humidité et aux moisissures. Lavable avec des détergents ordinaires et facile à entretenir en raison de ses propriétés antitaches et anti-rayures, le grès Lecce Stone est également adapté au contact avec les aliments.

Inspired by the color and texture of the traditional Salentine limestone rock, Lecce Stone stoneware is 6 mm thick and it is characterized by a compact, heatproof surface, particularly resistant to the weathering, moisture and mould. Washable using common household detergents and easy to maintain thanks to the stain resistant surface, Lecce Stone stoneware is also a material perfect for dining purposes.

Farbe und Materialität des traditionellen Salento-Kalksteins sind Quelle der Inspiration für das Feinsteinzeug Lecce Stone. Die 6 mm dicke Platte zeichnet sich durch eine kompakte, hitzebeständige und gegenüber atmosphärischen Einflüssen, Feuchtigkeit und Schimmel besonders beständige Oberfläche aus. Sie kann mit handelsüblichen Reinigungsmitteln gesäubert werden und ist dank der schmutzabweisenden und kratzfesten Beschaffenheit leicht zu pflegen. Feinsteinzeug eignet sich darüber hinaus für den direkten Kontakt mit Lebensmitteln.

Aluminium

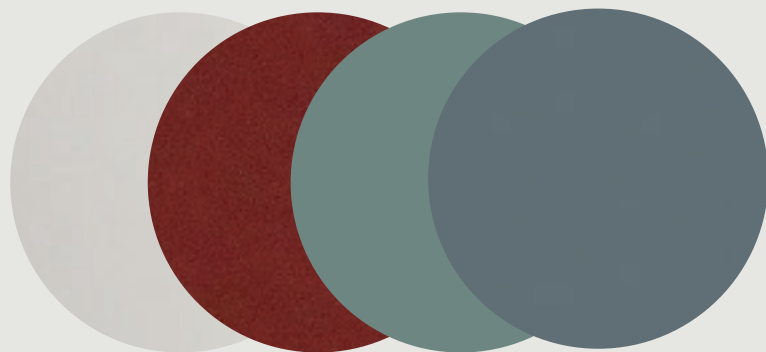

Oltre che espressivo ed ecologico, l'alluminio è un metallo unico per qualità tecniche. Tre volte più leggero dell'acciaio, è stabile nel tempo, resistente agli agenti atmosferici e di facile manutenzione. In più è riciclabile e può essere riutilizzato all'infinito, senza la minima alterazione delle sue proprietà tecniche e meccaniche. L'alluminio utilizzato nella collezione è oggetto di uno specifico pre-trattamento antisalino che inibisce il naturale processo di ossidazione. Il successivo procedimento di verniciatura a polvere aumenta la resistenza alla corrosione e protegge il metallo anche da graffi e scheggiature.

En plus d'être expressif et écologique, l'aluminium est un métal aux qualités techniques uniques. Trois fois plus léger que l'acier, il est stable dans le temps, résistant aux agents atmosphériques et facile d'entretien. Par ailleurs, il est recyclable et peut être réutilisé indéfiniment, sans la moindre altération de ses propriétés techniques ou mécaniques. L'aluminium employé dans cette collection fait l'objet d'un prétraitement anti-salin qui inhibe le processus naturel d'oxydation. L'étape successive, celle du vernissage en poudre, augmente la résistance à la corrosion et protège également le métal des rayures et des éclats.

In addition to being expressive and ecological, aluminium is also a unique metal in terms of technical qualities. Three times lighter than steel, it offers stability over time, resistance to the weathering and easy maintenance. Moreover, it is recyclable and can be reused an infinite number of times without the slightest alteration of its technical and mechanical properties. The aluminium of the collection has been processed using a specific anti-saline pre-treatment, which inhibits the natural oxidation process. The subsequent powder-coating process increases resistance to corrosion while also protecting the metal against scratches and chipping.

Aluminium ist nicht nur ausdrucksvoll und umweltfreundlich, sondern auch einzigartig, was seine technischen Eigenschaften angeht. Es ist dreimal leichter als Stahl, beständig im Laufe der Zeit, widersteht atmosphärischen Einflüssen und ist leicht zu pflegen. Darüber hinaus ist es recycelbar und kann immer weiter verwendet werden, ohne die geringste Beeinträchtigung seiner technischen und mechanischen Eigenschaften. Das für die Kollektion verwendete Aluminium ist Gegenstand einer besonderen Behandlung, die es gegenüber Salz beständig macht und den natürlichen Oxydationsprozess verhindert. Die folgende Pulverbeschichtung erhöht die Korrosionsbeständigkeit und schützt das Metall vor Kratzern und Absplitterungen.

Inout 143, 144, 155

(→)



Inout 143, 144, 155



Inout 143
p. 126-127, 128, 138-139, 140

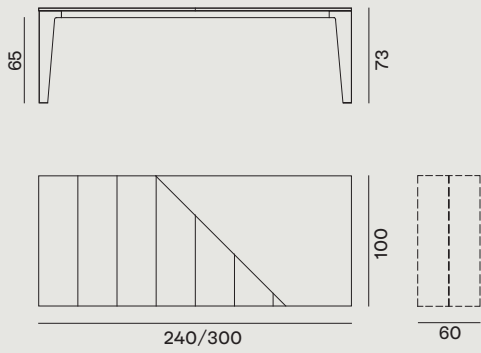

Inout 144

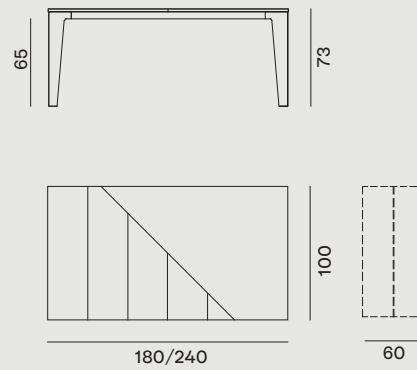

Inout 155
p. 120

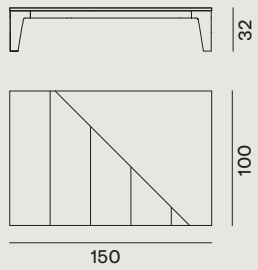

Top finishes



Legs finishes



Teak



Il Teak (*Tectona grandis*) è uno dei più pregiati legni tropicali con eccezionali caratteristiche di durezza, duttilità e resistenza agli agenti atmosferici, all'umidità, alla salsedine. La sua particolarità deriva dalla presenza di una resina oleosa che ne aumenta naturalmente il grado di impermeabilità e di resistenza anche a insetti e parassiti. Il Teak naturale utilizzato per realizzare la collezione proviene da foreste delle regioni tropicali del sud-est asiatico.

Teak (*Tectona grandis*) is one of the most precious tropical woods, having exceptional characteristics of hardness, ductility and resistance to the weathering, moisture and salt. Its uniqueness comes from an oily resin which naturally improves its impermeability and resistance, even to insects and parasites. The natural teak used to develop the collection originates from forests in the tropical regions of Southeast Asia.

Le teck (*Tectona Grandis*) est l'un des bois exotiques les plus prisés. Il possède d'incroyables propriétés de robustesse, de ductilité et de résistance aux agents atmosphériques, à l'humidité et au sel. Sa particularité lui vient de son oléorésine qui augmente naturellement son imperméabilité ainsi que sa résistance aux insectes et parasites. Le teck naturel utilisé pour réaliser cette collection provient de forêts des régions tropicales du sud-est asiatique.

Teak (*Tectona grandis*) ist eines der kostbarsten Tropenholzer und zeichnet sich durch außergewöhnliche Härte, Geschmeidigkeit und Widerstandsfähigkeit gegen atmosphärische Einflüsse, Feuchtigkeit und Salz aus. Seine besonderen Eigenschaften gehen auf ein öliges Harz zurück, das für seine natürliche Impermeabilität und Resistenz gegen Insekten und Parasiten sorgt. Das für die Kollektion verwendete Teak stammt aus Wäldern im tropischen Südostasien.

White Carrara Marble



Alle qualità estetiche, il marmo abbina caratteristiche strutturali, fisiche e morfologiche che lo rendono naturalmente compatto, resistente all'usura e idoneo al contatto con gli alimenti. Il marmo utilizzato in collezione è trattato con impregnante protettivo trasparente opaco.

The aesthetic qualities of marble are combined with structural, physical and morphological characteristics making it naturally compact, resistant to wear and suitable for contact with food. The marble used in the collection is treated with a clear matt protective impregnating agent.

Le marbre allie à ses qualités esthétiques des propriétés structurelles, physiques et morphologiques qui le rendent naturellement solide, résistant à l'usure et adapté au contact avec les aliments. Le marbre utilisé dans cette collection est protégé à l'aide d'un imprégnant transparent opaque.

Neben seinen ästhetischen Qualitäten verbindet der Marmor strukturelle, physische und morphologische Eigenschaften, dank derer er von Natur aus kompakt, widerstandsfähig und für den Kontakt mit Lebensmitteln geeignet ist. Der für die Kollektion verwendete Marmor wird mit einer matt-transparenten Schutzschicht imprägniert.

Lecce Stone stoneware



Ispirato al colore e alla matericità della tradizionale roccia calcarea Salentina, il gres Lecce Stone ha uno spessore di 6 mm ed è caratterizzato da una superficie compatta, refrattaria al calore e particolarmente resistente agli agenti atmosferici, all'umidità e alle muffe. Lavabile con detergenti comuni e facile da mantenere per le qualità antimacchia della superficie, il gres Lecce stone è anche un materiale idoneo al contatto con alimenti.

Inspired by the color and texture of the traditional Salentine limestone rock, Lecce Stone stoneware is 6 mm thick and it is characterized by a compact, heatproof surface, particularly resistant to the weathering, moisture and mould. Washable using common household detergents and easy to maintain thanks to the stain resistant surface, Lecce Stone stoneware is also a material perfect for dining purposes.

Le grès Lecce Stone s'inspire à la couleur et la matérialité du calcaire traditionnel du Salento. Le plateau d'une épaisseur de 6 mm présente une surface compacte, réfractaire à la chaleur et particulièrement résistante aux agents atmosphériques, à l'humidité et aux moisissures. Lavable avec des détergents ordinaires et facile à entretenir en raison de ses propriétés antitaches et anti-rayures, le grès Lecce Stone est également adapté au contact avec les aliments.

Farbe und Materialität des traditionellen Salento-Kalksteins sind Quelle der Inspiration für das Feinsteinzeug Lecce Stone. Die 6 mm dicke Platte zeichnet sich durch eine kompakte, hitzebeständige und gegenüber atmosphärischen Einflüssen, Feuchtigkeit und Schimmel besonders beständige Oberfläche aus. Sie kann mit handelsüblichen Reinigungsmitteln gesäubert werden und ist dank der schmutzabweisenden und kratzfesten Beschaffenheit leicht zu pflegen. Feinsteinzeug eignet sich darüber hinaus für den direkten Kontakt mit Lebensmitteln.

Aluminium

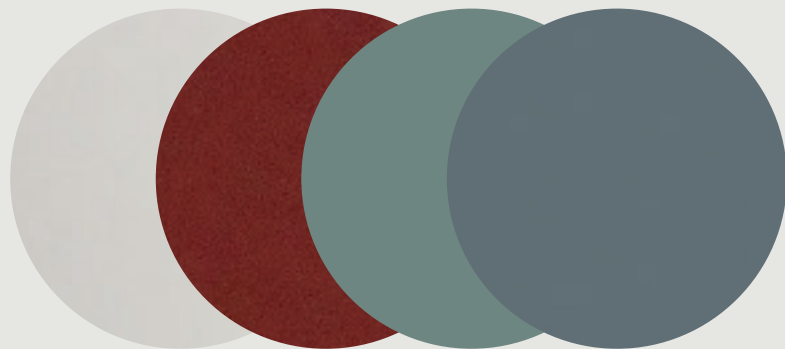

Oltre che espressivo ed ecologico, l'alluminio è un metallo unico per qualità tecniche. Tre volte più leggero dell'acciaio, è stabile nel tempo, resistente agli agenti atmosferici e di facile manutenzione. In più è riciclabile e può essere riutilizzato all'infinito, senza la minima alterazione delle sue proprietà tecniche e meccaniche. L'alluminio utilizzato nella collezione è oggetto di uno specifico pre-trattamento antisalino che inibisce il naturale processo di ossidazione. Il successivo procedimento di verniciatura a polvere aumenta la resistenza alla corrosione e protegge il metallo anche da graffi e scheggiature.

En plus d'être expressif et écologique, l'aluminium est un métal aux qualités techniques uniques. Trois fois plus léger que l'acier, il est stable dans le temps, résistant aux agents atmosphériques et facile d'entretien. Par ailleurs, il est recyclable et peut être réutilisé indéfiniment, sans la moindre altération de ses propriétés techniques ou mécaniques. L'aluminium employé dans cette collection fait l'objet d'un prétraitement anti-salin qui inhibe le processus naturel d'oxydation. L'étape successive, celle du vernissage en poudre, augmente la résistance à la corrosion et protège également le métal des rayures et des éclats.

In addition to being expressive and ecological, aluminium is also a unique metal in terms of technical qualities. Three times lighter than steel, it offers stability over time, resistance to the weathering and easy maintenance. Moreover, it is recyclable and can be reused an infinite number of times without the slightest alteration of its technical and mechanical properties. The aluminium of the collection has been processed using a specific anti-saline pre-treatment, which inhibits the natural oxidation process. The subsequent powder-coating process increases resistance to corrosion while also protecting the metal against scratches and chipping.

Aluminium ist nicht nur ausdrucksvoll und umweltfreundlich, sondern auch einzigartig, was seine technischen Eigenschaften angeht. Es ist dreimal leichter als Stahl, beständig im Laufe der Zeit, widersteht atmosphärischen Einflüssen und ist leicht zu pflegen. Darüber hinaus ist es recycelbar und kann immer weiter verwendet werden, ohne die geringste Beeinträchtigung seiner technischen und mechanischen Eigenschaften. Das für die Kollektion verwendete Aluminium ist Gegenstand einer besonderen Behandlung, die es gegenüber Salz beständig macht und den natürlichen Oxydationsprozess verhindert. Die folgende Pulverbeschichtung erhöht die Korrosionsbeständigkeit und schützt das Metall vor Kratzern und Absplitterungen.

Inout 834, 836

(→)



Inout 834, 836

Inout 834

Inout 836
p. 110, 218, 222

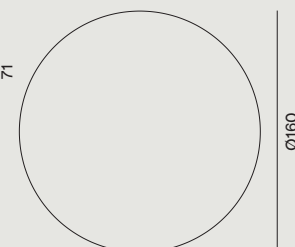
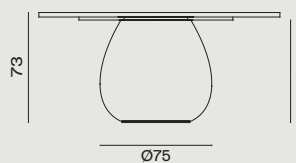
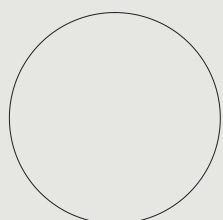
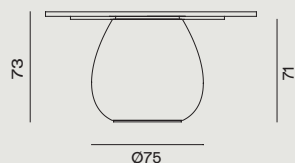

Top finishes



White Carrara
Marble

Base finishes



GRFC
Concrete

White Carrara Marble



Alle qualità estetiche, il marmo abbina caratteristiche strutturali, fisiche e morfologiche che lo rendono naturalmente compatto, resistente all'usura e idoneo al contatto con gli alimenti. Il marmo utilizzato in collezione è trattato con impregnante protettivo trasparente opaco.

Le marbre allie à ses qualités esthétiques des propriétés structurelles, physiques et morphologiques qui le rendent naturellement solide, résistant à l'usure et adapté au contact avec les aliments. Le marbre utilisé dans cette collection est protégé à l'aide d'un imprégnant transparent opaque.

The aesthetic qualities of marble are combined with structural, physical and morphological characteristics making it naturally compact, resistant to wear and suitable for contact with food. The marble used in the collection is treated with a clear matt protective impregnating agent.

Neben seinen ästhetischen Qualitäten verbindet der Marmor strukturelle, physische und morphologische Eigenschaften, dank derer er von Natur aus kompakt, widerstandsfähig und für den Kontakt mit Lebensmitteln geeignet ist. Der für die Kollektion verwendete Marmor wird mit einer matt-transparenten Schutzschicht imprägniert.

GRFC Concrete



Prodotti realizzati con una miscela di cemento e fibra di vetro. Il cemento GFRC si contraddistingue per una resistenza unica e una maggior durabilità nel tempo. Gli articoli vengono finiti con una verniciatura grigio opaco. La texture del cemento imita la matericità data dalle crepe che si formano su una superficie nel tempo.

Les produits sont réalisés avec un mélange de ciment et de fibre de verre et sont laqués en gris mat. Le produit final se distingue par sa résistance unique et une plus grande durabilité. La finition imite les craquelures qui se forment normalement sur la surface du béton au fil du temps.

Products made from fusion of concrete and glass fiber. The final product stands out for its unique strength and for a greater durability over time. The items are finished with a matt grey paint. The final texture draws the material effect of the cracks that form on a surface over time.

Die Produkte bestehen aus einer Mischung von Zement und Glasfaser, matt grau lackiert. Das Material zeichnet sich durch seine einzigartige Festigkeit sowie eine längere Lebensdauer aus. Die Ausführung mit dem Craqueureffekt ahmt die Risse nach, die sich normalerweise im Laufe der Zeit auf einer Betonoberfläche bilden.



Inout 837, 838



Inout 837
p. 194, 209, 246, 266

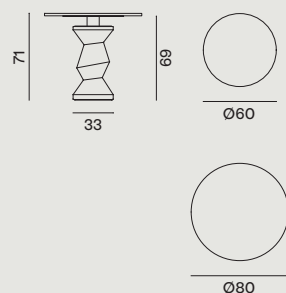

Inout 838
p. 194, 209, 246, 266

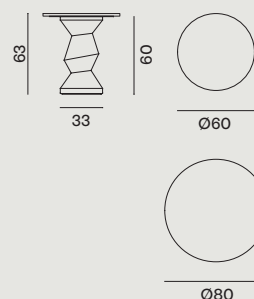

Top finishes



White Carrara
Marble

Base finishes

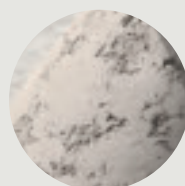

Crackle
Concrete

White Carrara Marble



Alle qualità estetiche, il marmo abbina caratteristiche strutturali, fisiche e morfologiche che lo rendono naturalmente compatto, resistente all'usura e idoneo al contatto con gli alimenti. Il marmo utilizzato in collezione è trattato con impregnante protettivo trasparente opaco.

The aesthetic qualities of marble are combined with structural, physical and morphological characteristics making it naturally compact, resistant to wear and suitable for contact with food. The marble used in the collection is treated with a clear matt protective impregnating agent.

Le marbre allie à ses qualités esthétiques des propriétés structurelles, physiques et morphologiques qui le rendent naturellement solide, résistant à l'usure et adapté au contact avec les aliments. Le marbre utilisé dans cette collection est protégé à l'aide d'un imprégnant transparent opaque.

Neben seinen ästhetischen Qualitäten verbindet der Marmor strukturelle, physische und morphologische Eigenschaften, dank derer er von Natur aus kompakt, widerstandsfähig und für den Kontakt mit Lebensmitteln geeignet ist. Der für die Kollektion verwendete Marmor wird mit einer matt-transparenten Schutzschicht imprägniert.

Crackle Concrete

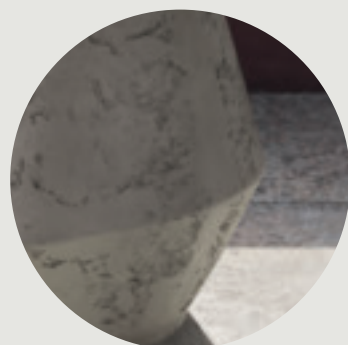

La finitura ricorda la craquelure che il tempo disegna sui materiali. L'effetto è ottenuto sovrapponendo più strati di vernice fra i quali viene steso un reagente che solleva parte dello strato più superficiale, lasciando intravedere quello sottostante. L'effetto craquelure che si ottiene dopo l'asciugatura e la cottura del cemento è sempre diverso e rende ogni base un pezzo unico.

This finish recalls the craquelure that appears on materials over time. The effect is obtained by overlapping multiple layers of paint, among with a reagent is spread, which lifts up partially the uppermost layer, bringing the underlying layer into view. The craquelure effect is obtained after the cement is dried and cooked. It is always different and makes each base a unique piece.

Cette finition rappelle les craquelures que le temps dessine sur les matériaux. L'effet est obtenu en superposant plusieurs couches de vernis entre lesquelles est appliqué un réactif qui soulève une partie de la couche la plus superficielle pour laisser entrevoir celle d'en dessous. Les craquelures que l'on obtient après séchage et cuisson du béton sont toujours différentes, ce qui rend chaque piètement unique.

Die Optik beruht auf dem Craquelure-Effekt, dem Materialien durch Alterung unterliegen. Er entsteht, indem mehrere Schichten Lack übereinandergelegt werden, in die ein Reagens eingefügt wird, das einen Teil der obersten Schicht anhebt, so dass die darunterliegenden Schichten zum Vorschein kommen. Da der Craquelure-Effekt, der nach der Trocknung und dem Brennen des Betons auftritt, jedesmal anders ist, ist jedes Gestell ein Einzelstück.

Inout 847, 848

(→)



Inout 847, 848



Inout 847
p. 136, 137, 196, 197

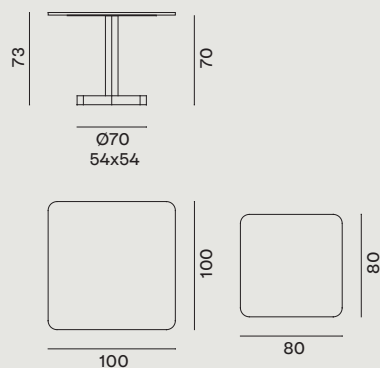

Inout 848

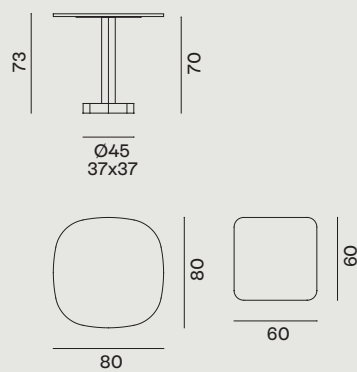

Top finishes

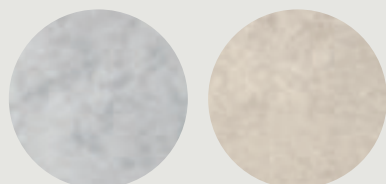

White Carrara
Marble

Lecce Stone
stoneware

Legs finishes

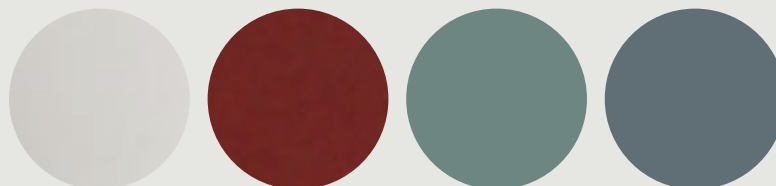

Aluminium
Pearl

Aluminium
Oxido

Aluminium
Agate

Aluminium
Slate

Aluminium

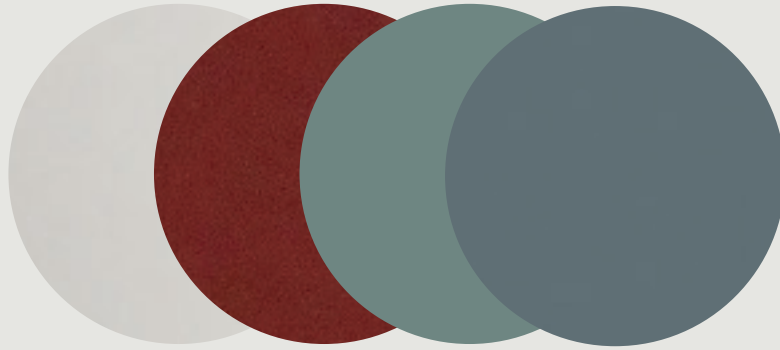

Oltre che espressivo ed ecologico, l'alluminio è un metallo unico per qualità tecniche. Tre volte più leggero dell'acciaio, è stabile nel tempo, resistente agli agenti atmosferici e di facile manutenzione. In più è riciclabile e può essere riutilizzato all'infinito, senza la minima alterazione delle sue proprietà tecniche e meccaniche. L'alluminio utilizzato nella collezione è oggetto di uno specifico pre-trattamento antisalino che inibisce il naturale processo di ossidazione. Il successivo procedimento di verniciatura a polvere aumenta la resistenza alla corrosione e protegge il metallo anche da graffi e scheggiature.

In addition to being expressive and ecological, aluminium is also a unique metal in terms of technical qualities. Three times lighter than steel, it offers stability over time, resistance to the weathering and easy maintenance. Moreover, it is recyclable and can be reused an infinite number of times without the slightest alteration of its technical and mechanical properties. The aluminium of the collection has been processed using a specific anti-saline pre-treatment, which inhibits the natural oxidation process. The subsequent powder-coating process increases resistance to corrosion while also protecting the metal against scratches and chipping.

En plus d'être expressif et écologique, l'aluminium est un métal aux qualités techniques uniques. Trois fois plus léger que l'acier, il est stable dans le temps, résistant aux agents atmosphériques et facile d'entretien. Par ailleurs, il est recyclable et peut être réutilisé indéfiniment, sans la moindre altération de ses propriétés techniques ou mécaniques. L'aluminium employé dans cette collection fait l'objet d'un prétraitement anti-salin qui inhibe le processus naturel d'oxydation. L'étape successive, celle du vernissage en poudre, augmente la résistance à la corrosion et protège également le métal des rayures et des éclats.

Aluminium ist nicht nur ausdrucksvoll und umweltfreundlich, sondern auch einzigartig, was seine technischen Eigenschaften angeht. Es ist dreimal leichter als Stahl, beständig im Laufe der Zeit, widersteht atmosphärischen Einflüssen und ist leicht zu pflegen. Darüber hinaus ist es recycelbar und kann immer weiter verwendet werden, ohne die geringste Beeinträchtigung seiner technischen und mechanischen Eigenschaften. Das für die Kollektion verwendete Aluminium ist Gegenstand einer besonderen Behandlung, die es gegenüber Salz beständig macht und den natürlichen Oxydationsprozess verhindert. Die folgende Pulverbeschichtung erhöht die Korrosionsbeständigkeit und schützt das Metall vor Kratzern und Absplitterungen.

White Carrara Marble



Alle qualità estetiche, il marmo abbina caratteristiche strutturali, fisiche e morfologiche che lo rendono naturalmente compatto, resistente all'usura e idoneo al contatto con gli alimenti. Il marmo utilizzato in collezione è trattato con impregnante protettivo trasparente opaco.

The aesthetic qualities of marble are combined with structural, physical and morphological characteristics making it naturally compact, resistant to wear and suitable for contact with food. The marble used in the collection is treated with a clear matt protective impregnating agent.

Le marbre allie à ses qualités esthétiques des propriétés structurelles, physiques et morphologiques qui le rendent naturellement solide, résistant à l'usure et adapté au contact avec les aliments. Le marbre utilisé dans cette collection est protégé à l'aide d'un imprégnant transparent opaque.

Neben seinen ästhetischen Qualitäten verbindet der Marmor strukturelle, physische und morphologische Eigenschaften, dank derer er von Natur aus kompakt, widerstandsfähig und für den Kontakt mit Lebensmitteln geeignet ist. Der für die Kollektion verwendete Marmor wird mit einer matt-transparenten Schutzschicht imprägniert.

Lecce Stone stoneware



Ispirato al colore e alla matericità della tradizionale roccia calcarea Salentina, il gres Lecce Stone ha uno spessore di 6 mm ed è caratterizzato da una superficie compatta, refrattaria al calore e particolarmente resistente agli agenti atmosferici, all'umidità e alle muffe. Lavabile con detergenti comuni e facile da manuteneere per le qualità antimacchia della superficie, il gres Lecce stone è anche un materiale idoneo al contatto con alimenti.

Le grès Lecce Stone s'inspire à la couleur et la matérialité du calcaire traditionnel du Salento. Le plateau d'une épaisseur de 6 mm présente une surface compacte, réfractaire à la chaleur et particulièrement résistante aux agents atmosphériques, à l'humidité et aux moisissures. Lavable avec des détergents ordinaires et facile à entretenir en raison de ses propriétés antitaches et anti-rayures, le grès Lecce Stone est également adapte au contact avec les aliments.

Inspired by the color and texture of the traditional Salentine limestone rock, Lecce Stone stoneware is 6 mm thick and it is characterized by a compact, heatproof surface, particularly resistant to the weathering, moisture and mould. Washable using common household detergents and easy to maintain thanks to the stain resistant surface, Lecce Stone stoneware is also a material perfect for dining purposes.

Farbe und Materialität des traditionellen Salento-Kalksteins sind Quelle der Inspiration für das Feinsteinzeug Lecce Stone. Die 6 mm dicke Platte zeichnet sich durch eine kompakte, hitzebeständige und gegenüber atmosphärischen Einflüssen, Feuchtigkeit und Schimmel besonders beständige Oberfläche aus. Sie kann mit handelsüblichen Reinigungsmitteln gesäubert werden und ist dank der schmutzabweisenden und kratzfesten Beschaffenheit leicht zu pflegen. Feinsteinzeug eignet sich darüber hinaus für den direkten Kontakt mit Lebensmitteln.

Jeko 31, 33, 34, 35





Jeko 31, 33, 34, 35

(→)

Jeko 31, 33, 34, 35



Jeko 31
p. 032

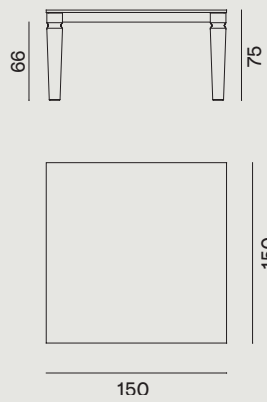

Jeko 33
p. 048-049, 051

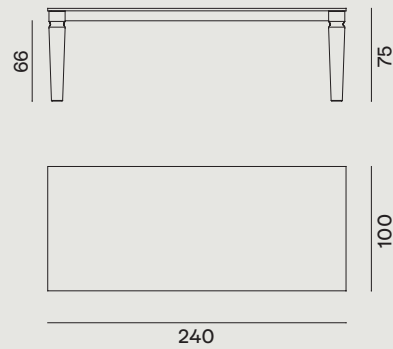

Jeko 34

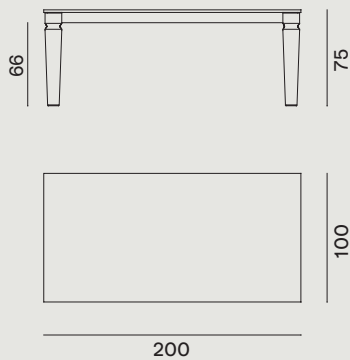

Jeko 35
p. 031, 035

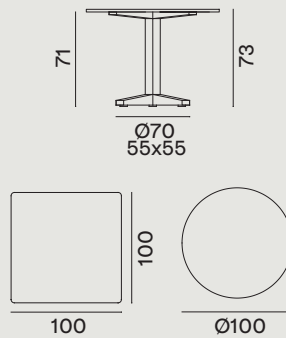

Top finishes



White Carrara
Marble

Legs finishes



ECOTEAK

White Carrara Marble



Alle qualità estetiche, il marmo abbina caratteristiche strutturali, fisiche e morfologiche che lo rendono naturalmente compatto, resistente all'usura e idoneo al contatto con gli alimenti. Il marmo utilizzato in collezione è trattato con impregnante protettivo trasparente opaco.

Le marbre allie à ses qualités esthétiques des propriétés structurelles, physiques et morphologiques qui le rendent naturellement solide, résistant à l'usure et adapté au contact avec les aliments. Le marbre utilisé dans cette collection est protégé à l'aide d'un imprégnant transparent opaque.

The aesthetic qualities of marble are combined with structural, physical and morphological characteristics making it naturally compact, resistant to wear and suitable for contact with food. The marble used in the collection is treated with a clear matt protective impregnating agent.

Neben seinen ästhetischen Qualitäten verbindet der Marmor strukturelle, physische und morphologische Eigenschaften, dank derer er von Natur aus kompakt, widerstandsfähig und für den Kontakt mit Lebensmitteln geeignet ist. Der für die Kollektion verwendete Marmor wird mit einer matt-transparenten Schutzschicht imprägniert.

ECOTEak



L'ECOTEak utilizzato per la collezione proviene dal riutilizzo di travi ed elementi in teak recuperati dalla demolizione delle tradizionali case in legno dell'isola di Giava, Indonesia. La finitura finale prevede la lucidatura a mano con panni di canapa e trucioli.

L'ECOTEak utilisé dans cette collection provient de poutres et d'éléments en teck récupérés lors de la démolition des maisons traditionnelles en bois de l'île indonésienne de Java. L'étape finale prévoit un cirage à la main à l'aide de tissus en chanvre et de copeaux.

The ECOTEak used in the collection is obtained from old teak beams and elements recovered from the demolition of traditional wooden homes on the Island of Java, in Indonesia. The final finish is obtained by hand polishing with hemp cloths and shavings.

Das ECO Teak, das für die Kollektion eingesetzt wird, geht auf wiederverwendete Balken und Elemente aus Teakholz zurück, die aus den abgerissenen traditionellen Holzhäusern der indonesischen Insel Java gewonnen werden. Das abschließende Finish basiert auf einer von Hand ausgeführten Politur mit Hanftüchern und Spänen.

Kasane 33, 35, 36

(→)



Kasane 33, 35, 36



Kasane 33
p. 056, 060-061

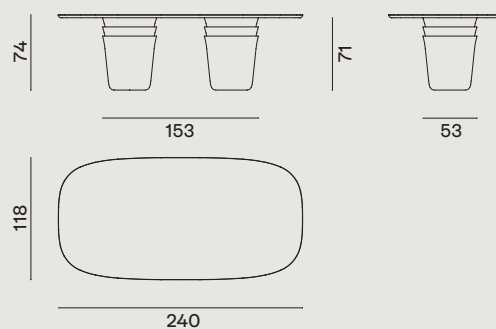

Kasane 35

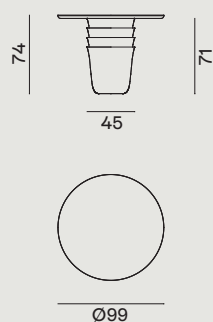

Kasane 36
p. 059, 062-063

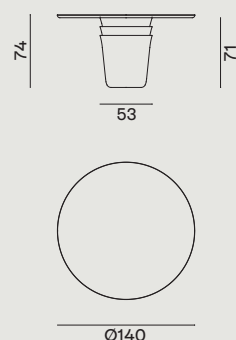

Finishes

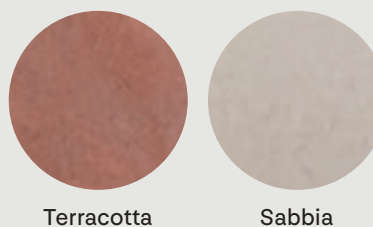

Terracotta

Sabbia

Polymer and clay

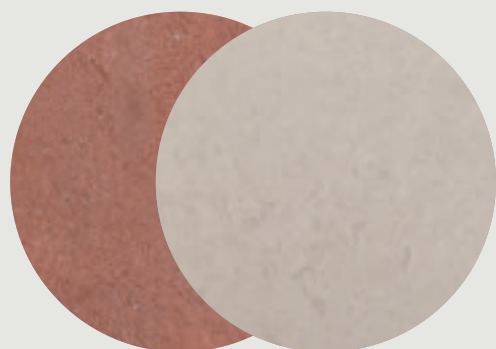

La basi dei tavoli e il pouf sono realizzati in polimero espanso, mentre i piani sono in MDF. Tutti gli articoli della collezione sono rivestiti con un sottile strato di argilla nei colori Terracotta e Sabbia. Grazie alla texture finale gli articoli esprimono matericità e una piacevole sensazione tattile.

Bases and pouf structures are made of polymer foam, while the table top is MDF. The products are covered with thin layer of clay in Terracotta and Sabbia colours. Thanks to the final texture, the articles express material nature and a pleasant tactile sensation.

Le piètement de la table et le pouf sont réalisés en polymère expansé, le plateau de la table est en MDF. Tous les produits sont revêtus d'une fine couche d'argile dans les couleurs Terracotta et Sabbia. Grâce à la texture finale, les éléments expriment la matérialité et donnent une agréable sensation tactile.

Der Tischunterbau und der Pouf sind aus expandiertem Polymer, die Tischplatte ist aus MDF. Für beide Modelle gibt es eine dünne Ton-Deckschicht in den Farben Terracotta und Sabbia. Dank der abschließenden Textur zeichnen sich die Artikel durch Materialität und eine angenehme Haptik aus.

Brise 33, 34, 38



Brise 33, 34, 38



Brise 33
p. 092, 096, 097

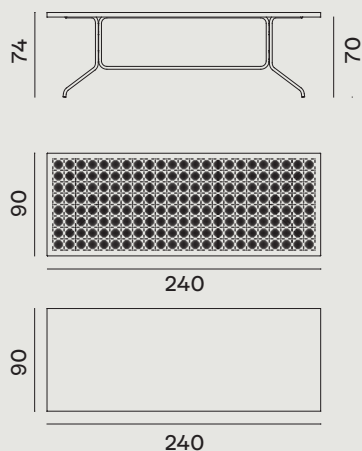

Brise 34

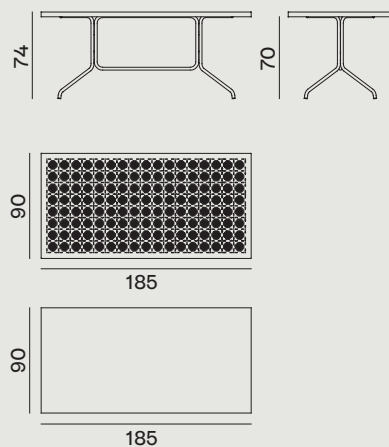

Brise 38
p. 089, 93

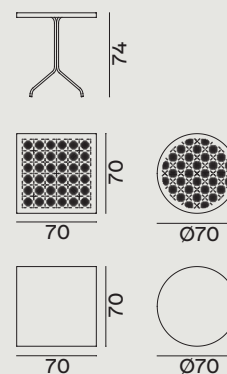

Top finishes



Concrete
White



Concrete
Grey



Stainless Steel
Pearl

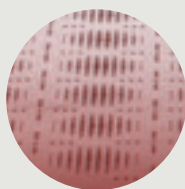

Stainless Steel
Oxido

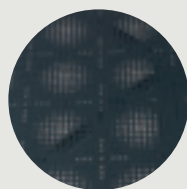

Stainless Steel
Slate

Legs finishes



Stainless Steel
Pearl



Stainless Steel
Oxido

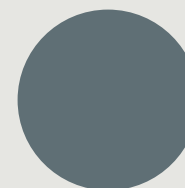

Stainless Steel
Slate

Brise 33, 34, 38

GFRC Concrete

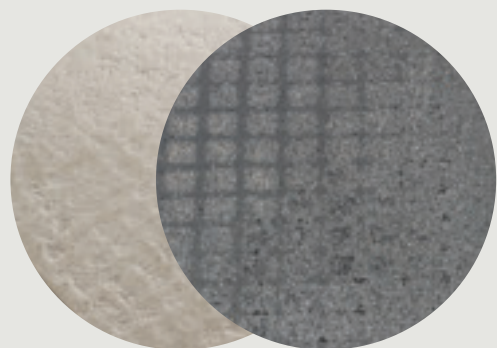

Prodotti realizzati con una miscela di cemento e fibra di vetro. Il prodotto finale si contraddistingue per una resistenza unica e una maggior durabilità nel tempo. I tavoli dining hanno il piano in cemento color bianco o grigio con decoro.

Les produits sont réalisés avec un mélange de béton et de fibre de verre. Le produit final se distingue par sa résistance unique et une plus grande durabilité dans le temps. Les tables ont un plateau en ciment blanc ou gris avec un décor géométrique.

Products made from mixture of concrete and glass fiber. The final product stands out for its unique strength and for a greater durability over time. Dining tables have a white or grey concrete top with geometric decoration.

Die Produkte bestehen aus einer Mischung von Zement und Glasfaser. Das Material zeichnet sich durch seine einzigartige Festigkeit sowie eine längere Lebensdauer aus. Die Esstische weisen eine Platte aus weißem oder grauem Zement mit geometrischem Dekor auf.

Stainless Steel

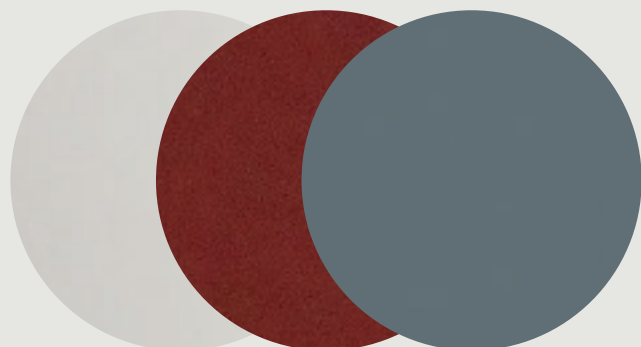

Caratterizzato da stabilità e forza, resistenza alla ruggine e a una maggiore resistenza all'ossidazione e alla corrosione, l'acciaio inox trattato per esterni è ampiamente utilizzato negli arredi outdoor. Il trattamento finale migliora la stabilità agli agenti atmosferici e all'inquinamento.

Caractérisé par stabilité et force, résistance à la rouille et une résistance accrue à l'oxydation et à la corrosion, l'acier inoxydable traité pour l'extérieur est largement utilisé pour le mobilier d'extérieur. Le traitement final améliore la stabilité aux agents atmosphériques et à la pollution.

Characterised by stability and strength, resistance to rust and a greater resistance to oxidation and corrosion, the stainless steel treated for outdoors is widely used in outdoor furnishings. The final treatment improves the stability to weather agents and to pollution.

Geprägt durch Stabilität und Kraft, Rostbeständigkeit und hohe Beständigkeit gegenüber Oxidation und Korrosion, wird der für Außenbereiche behandelte Edelstahl häufig in Outdoor-Umgebungen eingesetzt. Die Endbehandlung verbessert die Witterungs- und Schmutzbeständigkeit.

Chairs

Chairs

IT. Con le sedie si può osare ed è divertente mescolarne diversi stili. La libertà di comporre lo spazio intorno al tavolo all'aperto ispira la ricca proposta di sedie outdoor. Realizzate in tondino di acciaio, legno e intrecci resistenti alle condizioni esterne, declinano l'eleganza e il comfort in chiave open air.

EN.

With chairs, one can dare, and it's fun to mix up lots of different types. The freedom of composing the space around an outdoor table inspires the offer for outdoor seating. Made from steel tubes, wood and synthetic weaving fibres resistant to outdoor conditions, they articulate elegance and comfort in an open air key.

FR.

Avec les chaises on peut oser et il est amusant de mélanger plein de modèles différents. C'est cette liberté de composer l'espace autour de la table de jardin qui inspire notre choix de chaises d'extérieur. Réalisées en tiges d'acier, en bois et en fibres synthétiques tressées résistantes aux conditions extérieures, elles déclinent l'élégance et le confort dans le domaine du mobilier d'extérieur.

DE.

Stühle laden dazu ein, etwas zu wagen, und es macht Spaß, viele unterschiedliche Modelle zu kombinieren. Diese Freiheit, den Raum um den Tisch zusammenzustellen, inspiriert das Angebot von Stühlen für den Außenbereich. Die wetterfesten, aus Stahlrohr, Holz oder geflochtenen Synthetikfasern geschaffenen Stühle verbinden Eleganz und Komfort in der Outdoor-Version.

Inout 823, 824, 828, 855

(→)



Inout 823, 824, 828, 855

(→)

Inout 823, 824, 828



Inout 823
p. 096, 097, 106, 108, 114, 126, 128

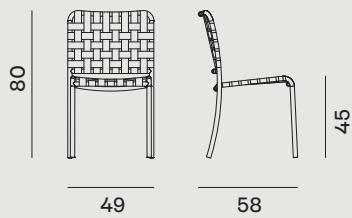

Inout 824
p. 048, 097, 110, 112, 136

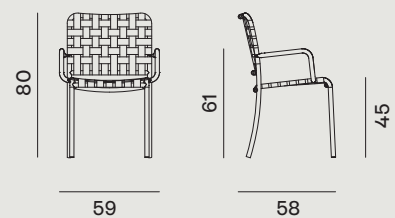

Inout 828
p. 118, 119

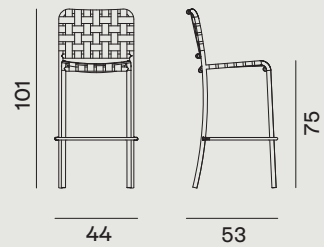

Inout 855

p. 106-107, 109

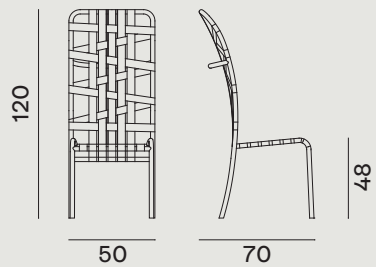
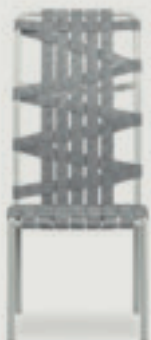

Elastic Belt

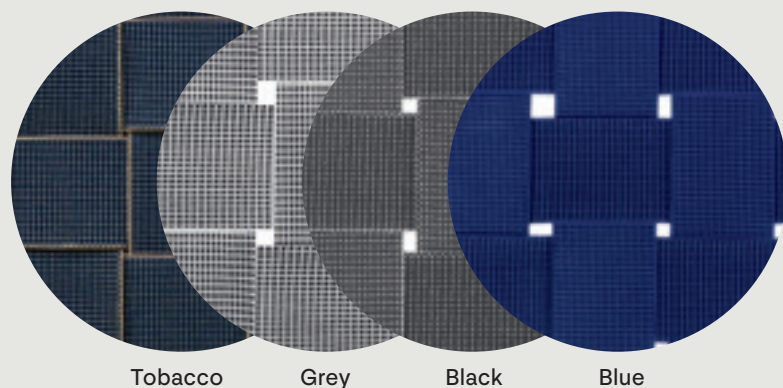

Tobacco

Grey

Black

Blue

La cinghia elastica utilizzata per la collezione è un prodotto innovativo sviluppato per l'outdoor. La struttura a base di gomma sintetica e propilene trattato per uso esterno garantisce la durata e la resistenza nel tempo a fenomeni di scolorimento e deterioramento provocati da agenti atmosferici e inquinanti. Il processo di fabbricazione altamente specializzato garantisce la rispondenza del prodotto ai requisiti di elasticità e tenuta.

La sangle élastique utilisée pour cette collection est un produit innovant développé pour l'extérieur. Sa structure, a base de caoutchouc synthétique et de propylène traité pour un usage extérieur, garantit sa durée et sa résistance dans le temps aux phénomènes de décoloration et de détérioration provoqués par les agents atmosphériques et polluants. Le procédé de fabrication hautement spécialisé permet au produit de répondre à des exigences d'élasticité et de tenue.

The elastic belt used in the collection is an innovative product specifically developed for outdoor furniture. The structure, made from synthetic rubber and propylene treated for outdoor use, guarantees durability and resistance over time against fading and deterioration caused by the weathering and pollutants. The highly specialized manufacturing process ensures the product satisfies requirements of elasticity and hold.

Die für die Kollektion verwendeten elastischen Gurte sind ein innovatives Produkt, das für die Verwendung im Freien entwickelt wurde. Die Struktur aus synthetischem Gummi und für den Outdoor-Gebrauch behandeltem Propylen gewährleistet Lebensdauer und Widerstandsfähigkeit gegenüber atmosphärischen Einflüssen und Umweltbelastung. Dank des hochspezialisierten Herstellungsprozesses verbindet das Produkt Elastizität und Festigkeit.

Aluminium

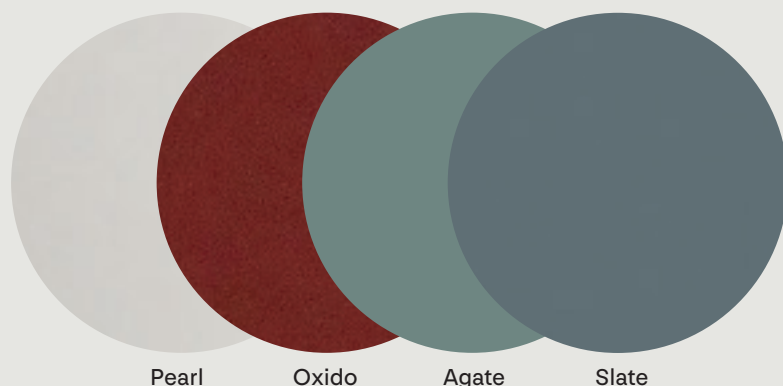

Pearl

Oxido

Agate

Slate

Oltre che espressivo ed ecologico, l'alluminio è un metallo unico per qualità tecniche. Tre volte più leggero dell'acciaio, è stabile nel tempo, resistente agli agenti atmosferici e di facile manutenzione. In più è riciclabile e può essere riutilizzato all'infinito, senza la minima alterazione delle sue proprietà tecniche e meccaniche. L'alluminio utilizzato nella collezione è oggetto di uno specifico pre-trattamento antisalinico che inibisce il naturale processo di ossidazione. Il successivo procedimento di verniciatura a polvere aumenta la resistenza alla corrosione e protegge il metallo anche da graffi e scheggiature.

En plus d'être expressif et écologique, l'aluminium est un métal aux qualités techniques uniques. Trois fois plus léger que l'acier, il est stable dans le temps, résistant aux agents atmosphériques et facile d'entretien. Par ailleurs, il est recyclable et peut être réutilisé indéfiniment, sans la moindre altération de ses propriétés techniques ou mécaniques. L'aluminium employé dans cette collection fait l'objet d'un prétraitement anti-salin qui inhibe le processus naturel d'oxydation. L'étape successive, celle du vernissage en poudre, augmente la résistance à la corrosion et protège également le métal des rayures et des éclats.

In addition to being expressive and ecological, aluminium is also a unique metal in terms of technical qualities. Three times lighter than steel, it offers stability over time, resistance to the weathering and easy maintenance. Moreover, it is recyclable and can be reused an infinite number of times without the slightest alteration of its technical and mechanical properties. The aluminium of the collection has been processed using a specific anti-saline pre-treatment, which inhibits the natural oxidation process. The subsequent powder-coating process increases resistance to corrosion while also protecting the metal against scratches and chipping.

Aluminium ist nicht nur ausdrucksvoll und umweltfreundlich, sondern auch einzigartig, was seine technischen Eigenschaften angeht. Es ist dreimal leichter als Stahl, beständig im Laufe der Zeit, widersteht atmosphärischen Einflüssen und ist leicht zu pflegen. Darüber hinaus ist es recycelbar und kann immer weiter verwendet werden, ohne die geringste Beeinträchtigung seiner technischen und mechanischen Eigenschaften. Das für die Kollektion verwendete Aluminium ist Gegenstand einer besonderen Behandlung, die es gegenüber Salz beständig macht und den natürlichen Oxydationsprozess verhindert. Die folgende Pulverbeschichtung erhöht die Korrosionsbeständigkeit und schützt das Metall vor Kratzern und Absplitterungen.

Ghost Out 23, 25

(→)



Ghost Out 23, 25



Ghost Out 23

p. 032, 060-061, 092-093, 126-127

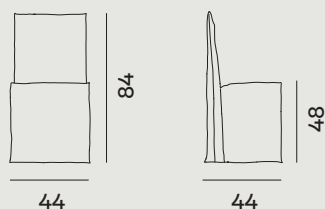

Ghost Out 25

p. 196

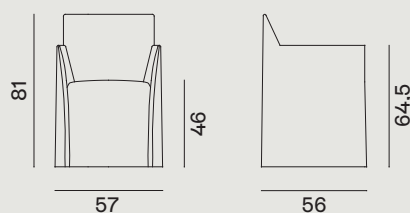

Upholstery

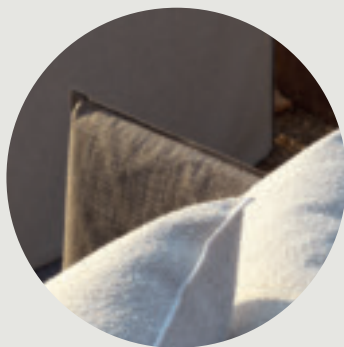

Braccioli e schienale sono separati dalla seduta per permettere il deflusso dell'acqua. Le imbottiture e i tessuti di rivestimento sono stati appositamente sviluppati per resistere all'acqua e alla luce solare. La perfetta impermeabilizzazione delle imbottiture in poliuretano espanso è garantita dal rivestimento con fodere in poliestere, trattate con specifici prodotti idrofughi e idrorepellenti, e dalle cuciture termonastrate.

Les accoudoirs et le dossier sont séparés de l'assise pour permettre à l'eau de s'écouler et éviter ainsi une stagnation de l'humidité. De même, le garnissage et les tissus de revêtement ont été spécialement développés pour résister à l'eau et à la lumière du soleil. Le garnissage en polyuréthane expansé est parfaitement imperméabilisé grâce à des housses en polyester aux propriétés hydrofuges et hydrophobes et grâce aux coutures thermosoudées.

Armrests and backs are separated from the seat to allow the water to drain and avoid the build-up of moisture. Likewise, the padding and upholstery fabrics have been specifically developed to resist against water and sunlight. The perfect water-repellence of the polyurethane foam padding is guaranteed by the polyester cushion covers, treated with specific waterproof and water-repellent products, and the heat welded seams.

Die Arm- und Rückenlehnen sind nicht mit der Sitzfläche verbunden, damit das Wasser abfließen kann und sich keine Feuchtigkeit ansammelt. Auch die Polsterung und die Stoffe wurden entwickelt, um sowohl gegenüber Wasser wie Sonnenlicht beständig zu sein. Die vollkommene Impermeabilisierung der Füllungen aus geschäumten Polyurethan wird durch die Polyester-Bezüge, die mit speziellen wasserabweisenden Produkten behandelt wurden, und die Thermobandierung gewährleistet.



Jeko 24

p. 031, 032, 035

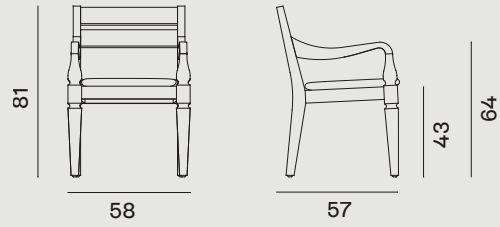

ECOTEak



L'ECOTEak utilizzato per la collezione proviene dal riutilizzo di travi ed elementi in teak recuperati dalla demolizione delle tradizionali case in legno dell'isola di Giava, Indonesia. La finitura finale prevede la lucidatura a mano con panni di canapa e trucioli.

The ECOTEak used in the collection is obtained from old teak beams and elements recovered from the demolition of traditional wooden homes on the Island of Java, in Indonesia. The final finish is obtained by hand polishing with hemp cloths and shavings.

L'ECOTEak utilisé dans cette collection provient de poutres et d'éléments en teck récupérés lors de la démolition des maisons traditionnelles en bois de l'île indonésienne de Java. L'étape finale prévoit un cirage à la main à l'aide de tissus en chanvre et de copeaux.

Das ECO Teak, das für die Kollektion eingesetzt wird, geht auf wiederverwendete Balken und Elemente aus Teakholz zurück, die aus den abgerissenen traditionellen Holzhäusern der indonesischen Insel Java gewonnen werden. Das abschließende Finish basiert auf einer von Hand ausgeführten Politur mit Hanftüchern und Spänen.

Brise 23, 24

(→)



Brise 23, 24



Brise 23
p. 059, 062, 090, 138

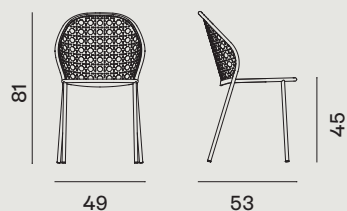

Brise 24
p. 059, 062, 090, 138

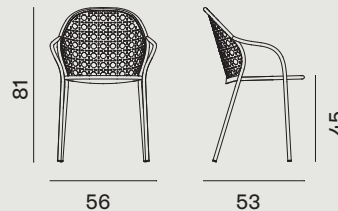

Wood Evolution™

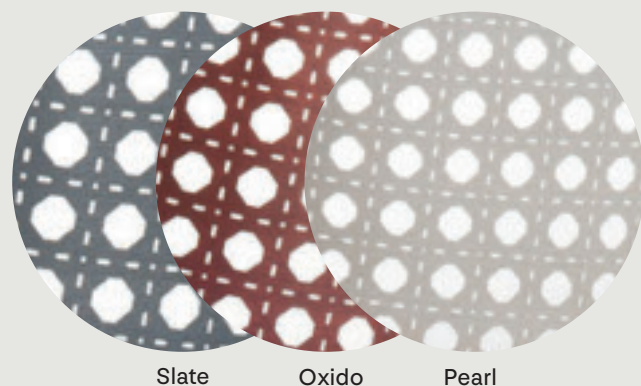

Materiale composito derivante dal legno naturale, il Wood Evolution™ è caratterizzato da una forte resistenza all'usura e agli agenti atmosferici. Brevettato e impiegato nel mondo dello sci, è un materiale sostenibile che elimina l'utilizzo dei classici materiali plastici, e permette di sfruttare al massimo spessori molto fini.

Composite material from natural wood, Wood Evolution™ has strong resistance to physical stress and weather agents. Patented and used in the ski world, it is a sustainable material that eliminates the use of classic plastic elements and that makes it possible to make the most of very fine thicknesses.

Matériau composite dérivé du bois naturel, le Wood Evolution™ est caractérisé par une forte résistance à l'usure et aux agents atmosphériques. Breveté et utilisé dans le monde du ski, c'est un matériau durable qui élimine l'utilisation des matières plastiques classiques et permet d'utiliser au maximum des épaisseurs très fines.

Als Verbundmaterial aus Naturholz gewährleistet Wood Evolution™ große Verschleiß- und Witterungsbeständigkeit. In der Skiwelt patentiert und eingesetzt, ist es ein nachhaltiges Material, das den Verzicht auf die klassischen Kunststoffmaterialien und eine maximale Ausnutzung sehr feiner Stärken erlaubt.

Stainless Steel

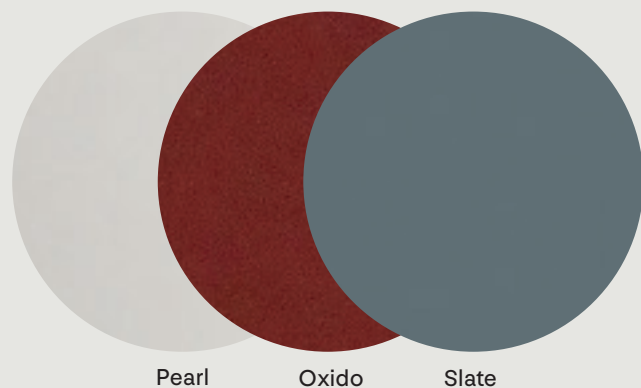

Caratterizzato da stabilità e forza, resistenza alla ruggine e a una maggiore resistenza all'ossidazione e alla corrosione, l'acciaio inox trattato per esterni è ampiamente utilizzato negli arredi outdoor. Il trattamento finale migliora la stabilità agli agenti atmosferici e all'inquinamento.

Characterised by stability and strength, resistance to rust and a greater resistance to oxidation and corrosion, the stainless steel treated for outdoors is widely used in outdoor furnishings. The final treatment improves the stability to weather agents and to pollution.

Caractérisé par stabilité et force, résistance à la rouille et une résistance accrue à l'oxydation et à la corrosion, l'acier inoxydable traité pour l'extérieur est largement utilisé pour le mobilier d'extérieur. Le traitement final améliore la stabilité aux agents atmosphériques et à la pollution.

Geprägt durch Stabilität und Kraft, Rostbeständigkeit und hohe Beständigkeit gegenüber Oxidation und Korrosion, wird der für Außenbereiche behandelte Edelstahl häufig in Outdoor-Umgebungen eingesetzt. Die Endbehandlung verbessert die Witterungs- und Schmutzbeständigkeit.

Straw 23, 24



Straw 23, 24



Straw 23
p. 221, 222, 225

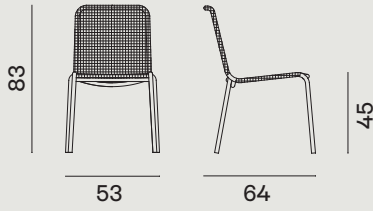

Straw 24
p. 218, 221, 222, 225

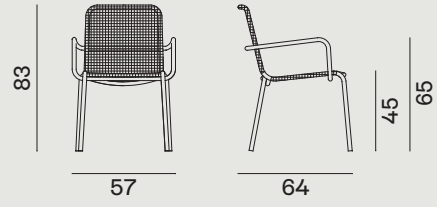

Straw 23, 24

Straw Resin



L'intreccio della collezione è realizzato con una corda in polietilene a doppia torsione (Straw resin). Appositamente progettata per l'outdoor, è una fibra dall'aspetto naturale, forte, flessibile e durevole, conforme agli standard più severi in termini di resistenza alle radiazioni solari, all'umidità e all'acqua (anche acqua di mare e acqua clorata). Straw resin è realizzata con polietilene ad alta densità e coloranti inorganici ed ecologici, in conformità alla normativa internazionale REACH in tema di gestione dei rischi delle sostanze chimiche. La qualità ecologica del materiale e dei processi produttivi è convalidata dalla certificazione STANDARD 100 by OEKO-TEX®. Straw resin è 100% riciclabile.

The weave of this collection is developed using a double twist rope (Straw resin) in polyethylene. Specifically designed for outdoor furniture, the fiber is characterised by its natural appearance, strength, flexibility and durability and satisfies the strictest standards in terms of solar radiation-resistance, moisture and water (including sea water and chlorinated water). Straw resin is made with high-density polyethylene and inorganic, ecological dyes in compliance with the international REACH standard concerning the management of risks linked to chemical substances. The ecological quality of this material and of the manufacturing process is validated by OEKO-TEX® STANDARD 100 certification. Straw resin is 100% recyclable.

Le tressage de cette collection est réalisé à l'aide d'une corde à double torsion (Straw resin) en fibre synthétique. Spécifiquement conçue pour l'extérieur, il s'agit d'une fibre d'aspect naturel, solide, flexible et durable, conforme aux standards les plus exigeants en termes de résistance aux rayonnements solaires, à l'humidité et à l'eau (y compris à l'eau de mer et à l'eau chlorée). Cette fibre est réalisée à base de polyéthylène haute densité et de colorants inorganiques et écologiques, conformément à la réglementation internationale REACH en matière de gestion des risques liés aux substances chimiques. La qualité écologique des produits et des procédés de fabrication est garantie par la certification STANDARD 100 by OEKO-TEX®. Elle est 100 % recyclable.

Das Flechtwerk der Kollektion wird aus einem doppelt gedrehten Seil (Straw resin) aus Polyethylen, das speziell für den Outdoor- Gebrauch entwickelt wurde, hergestellt. Es handelt sich um eine natürlich wirkende, starke, flexible und langlebige Faser, die den strengsten Standards hinsichtlich der Widerstandsfähigkeit gegenüber Sonnenstrahlen, Feuchtigkeit und Wasser (einschließlich Meerwasser und gechlortem Wasser) entspricht. Straw resin wird aus Polyethylen bester Qualität mit anorganischen, ökologischen Farbstoffen hergestellt, gemäß der internationalen REACH-Norm zum Umgang mit chemischen Stoffen. Die umweltfreundliche Qualität der Produkte und der Produktionsprozesse wird durch die Zertifizierung STANDARD 100 by OEKO-TEX® garantiert. Straw resin ist 100 % recycelbar.

Aluminum



Slate

Oltre che espressivo ed ecologico, l'alluminio è un metallo unico per qualità tecniche. Tre volte più leggero dell'acciaio, e stabile nel tempo, resistente agli agenti atmosferici e di facile manutenzione. In più è riciclabile e può essere riutilizzato all'infinito, senza la minima alterazione delle sue proprietà tecniche e meccaniche. L'alluminio utilizzato nella collezione è oggetto di uno specifico pre-trattamento antisalinico che inibisce il naturale processo di ossidazione. Il successivo procedimento di verniciatura a polvere aumenta la resistenza alla corrosione e protegge il metallo anche da graffi e scheggiature.

In addition to being expressive and ecological, aluminum is also a unique metal in terms of technical qualities. Three times lighter than steel, it offers stability over time, resistance to the weathering and easy maintenance. Moreover, it is recyclable and can be reused an infinite number of times without the slightest alteration of its technical and mechanical properties. The aluminum of the collection has been processed using a specific anti-saline pretreatment, which inhibits the natural oxidation process. The subsequent powder-coating process increases resistance to corrosion while also protecting the metal against scratches and chipping.

En plus d'être expressif et écologique, l'aluminium est un métal aux qualités techniques uniques. Trois fois plus léger que l'acier, il est stable dans le temps, résistant aux agents atmosphériques et facile d'entretien. Par ailleurs, il est recyclable et peut être réutilisé indéfiniment, sans la moindre altération de ses propriétés techniques ou mécaniques. L'aluminium employé dans cette collection fait l'objet d'un prétraitement anti-salin qui inhibe le processus naturel d'oxydation. L'étape successive, celle du vernissage en poudre, augmente la résistance à la corrosion et protège également le métal des rayures et des éclats.

Aluminium ist nicht nur ausdrucksvoll und umweltfreundlich, sondern auch einzigartig, was seine technischen Eigenschaften angeht. Es ist dreimal leichter als Stahl, beständig im Laufe der Zeit, widersteht atmosphärischen Einflüssen und ist leicht zu pflegen. Darüber hinaus ist es recycelbar und kann immer weiter verwendet werden, ohne die geringste Beeinträchtigung seiner technischen und mechanischen Eigenschaften. Das für die Kollektion verwendete Aluminium ist Gegenstand einer besonderen Behandlung, die es gegenüber Salz beständig macht und den natürlichen Oxydationsprozess verhindert. Die folgende Pulverbeschichtung erhöht die Korrosionsbeständigkeit und schützt das Metall vor Kratzern und Absplitterungen.

Complements

Complements

IT. Decorare uno spazio a propria immagine e somiglianza. Godersi a pieno il mondo en plain air è sinonimo di personalizzazione: lampade, tappeti e tavolini a servizio della propria creatività, in una miscela di diversi materiali, permettono di vivere l'outdoor come uno spazio domestico, in cui ritrovare il confort di casa.

EN.

Decorate a space in your own image and likeness. Fully enjoying the world en plain air is synonymous with personalisation: lamps, carpets and coffee tables at the service of your creativity, in a combination of different materials, allow you to experience the outdoors as a domestic space, one in which to find the comfort of home.

FR.

Décorez un espace à votre image qui vous ressemble. Profiter pleinement du monde en plein air est synonyme de personnalisation: des lampes, des tapis et des tables au service de votre créativité et déclinés dans un mélange de différents matériaux, qui vous permettent de vivre l'extérieur comme un espace domestique, où redécouvrir le confort de la maison.

DE.

Die Dekoration eines Raumes nach dem eigenen Ebenbild. Der volle Genuss der Außenräume ist Synonym für Personalisierung: Lampen, Teppiche und Beistelltische im Dienste der Kreativität in einer Mischung aus verschiedenen Materialien ermöglichen es, Outdoor-Bereiche wie Wohnräume zu leben und dort den Komfort des Heims vorzufinden.

Inout 41, 42, 43, 44, 91, 92

(→)



Inout 41, 42, 43, 44, 91, 92



Inout 41, 42, 43



Inout 41
p. 042, 123, 124, 131, 177

Inout 42
p. 042, 049, 123, 124, 177

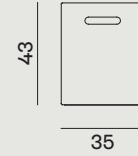
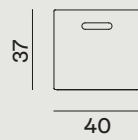

Inout 43
p. 042, 123, 177, 208, 210

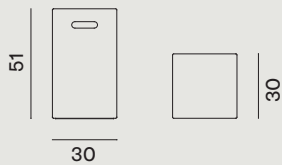

Finishes



GRFC Concrete White

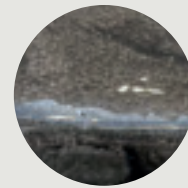

GRFC Concrete Grey

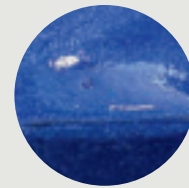

GRFC Concrete Blue

Inout 44

p. 046, 143, 188, 205, 207

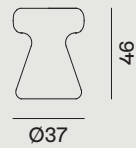

Finishes



GRFC Concrete White

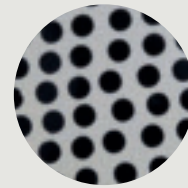

GRFC Concrete Dots



GRFC Concrete Stripes



GRFC Concrete Black

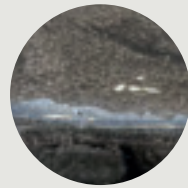

GRFC Concrete Grey

Inout 91, 92

Inout 91
p. 046, 122, 135, 190

Inout 92
p. 046, 122, 135, 190



Finishes



GRFC Concrete White

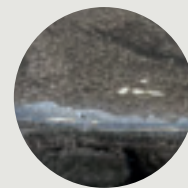

GRFC Concrete Grey

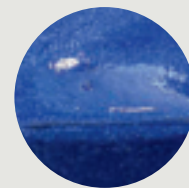

GRFC Concrete Blue

GRFC Concrete

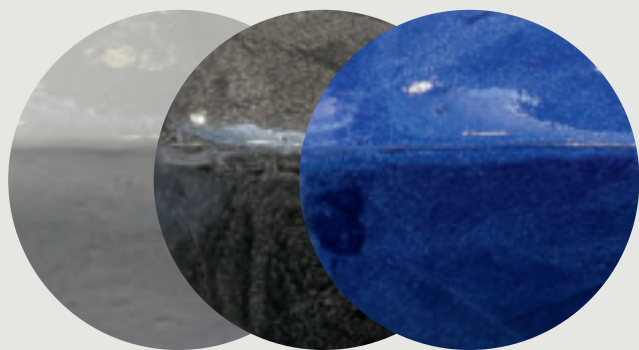

Prodotti realizzati con una miscela di cemento e fibra di vetro verniciati nei colori bianco, nero, blu o grigio antracite con finitura lucida. Il prodotto finale si contraddistingue per una resistenza unica e una maggior durabilità nel tempo.

Les produits sont réalisés avec un mélange de béton et de fibre de verre en blanc, noir, bleu ou gris anthracite, finition brillante. Le produit final se distingue par sa résistance unique et une plus grande durabilité dans le temps.

Products made with a mixture of concrete and glass fiber, white, black, blue or anthracite gray glossy lacquered. The final product stands out for its unique strength and for a greater durability over time.

Die Produkte bestehen aus einer Mischung von Zement und Glasfaser, weiß, schwarz, blau oder anthrazit grau glänzend lackiert. Das Material zeichnet sich durch seine einzigartige Festigkeit sowie eine längere Lebensdauer aus.

Inout 47, 48, 49

(→)

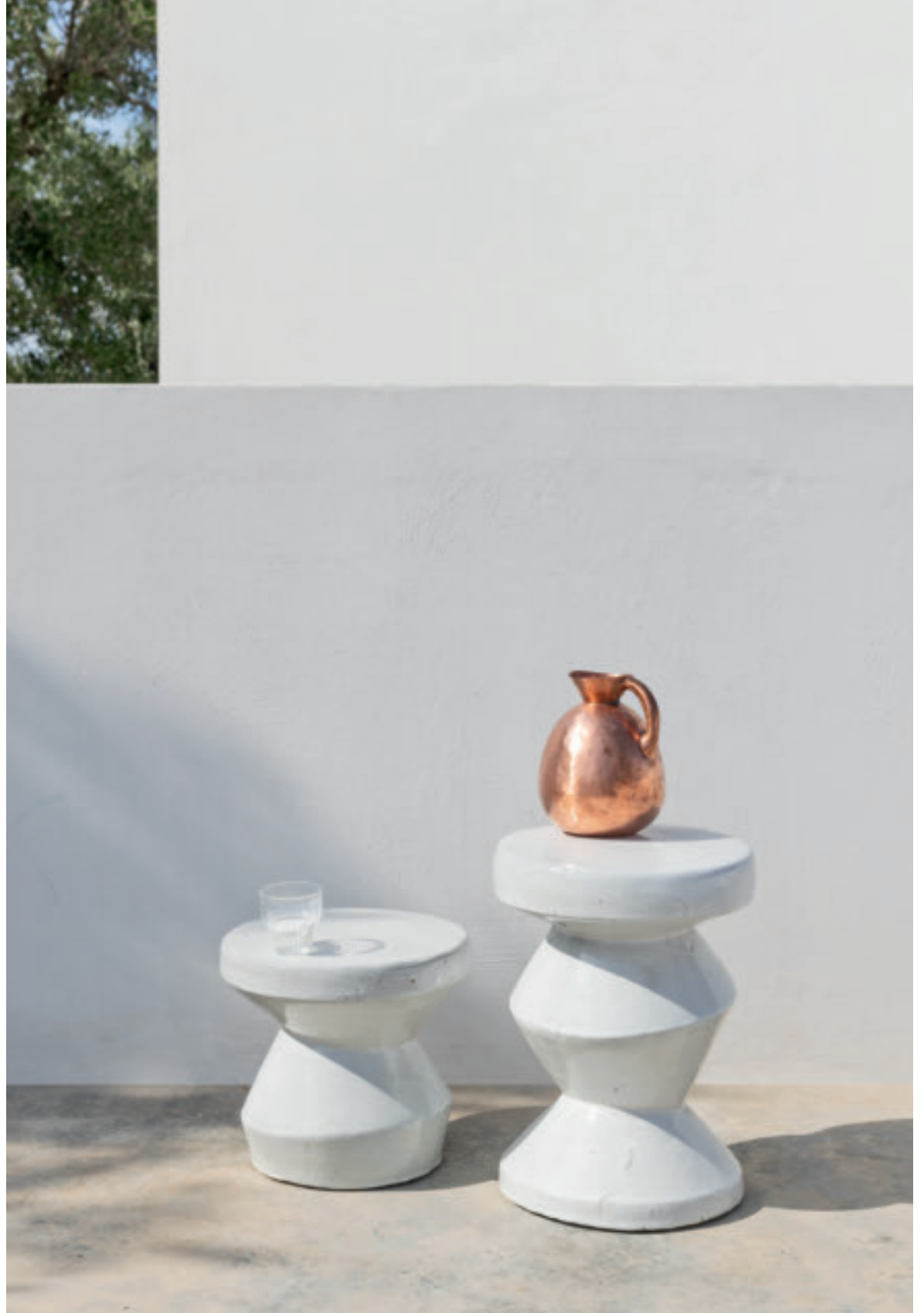

Inout 47, 48, 49



Inout 47
p. 038, 041, 116, 171, 174, 205

Inout 48
p. 038, 116, 120, 177, 179, 212

Inout 49
p. 038, 041, 116, 130, 135, 188

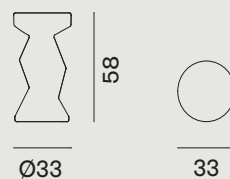
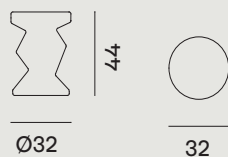

GRFC Concrete

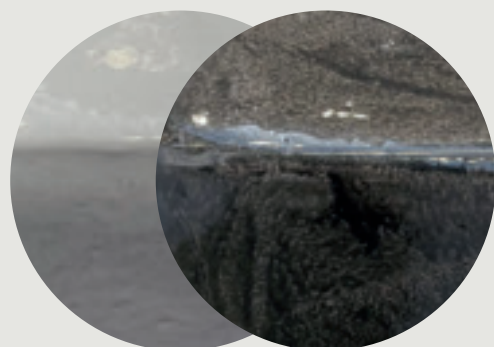

White

Anthracite
Grey

Prodotti realizzati con una miscela di cemento e fibra di vetro verniciati nei colori bianco o grigio antracite con finitura lucida. Il prodotto finale si contraddistingue per una resistenza unica e una maggior durabilità nel tempo.

Products made with a mixture of concrete and glass fiber, white or anthracite gray glossy lacquered. The final product stands out for its unique strength and for a greater durability over time.

Les produits sont réalisés avec un mélange de béton et de fibre de verre en blanc ou gris anthracite, finition brillante. Le produit final se distingue par sa résistance unique et une plus grande durabilité dans le temps.

Die Produkte bestehen aus einer Mischung von Zement und Glasfaser, weiß oder anthrazit grau glänzend lackiert. Das Material zeichnet sich durch seine einzigartige Festigkeit sowie eine längere Lebensdauer aus.

Heiko 41, 42, 43, 44

(→)





Heiko 41

Heiko 42
p. 172-173

Heiko 43
p. 172-173

Heiko 44

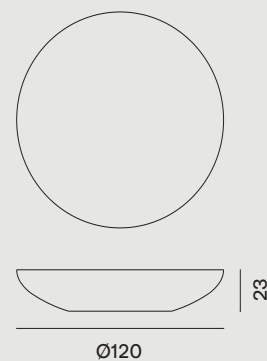
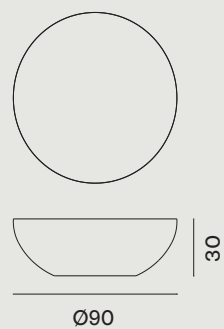
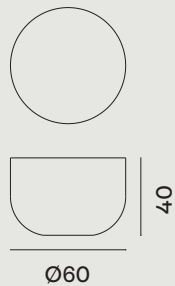
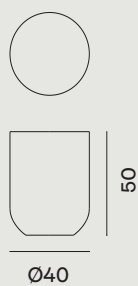

Clay

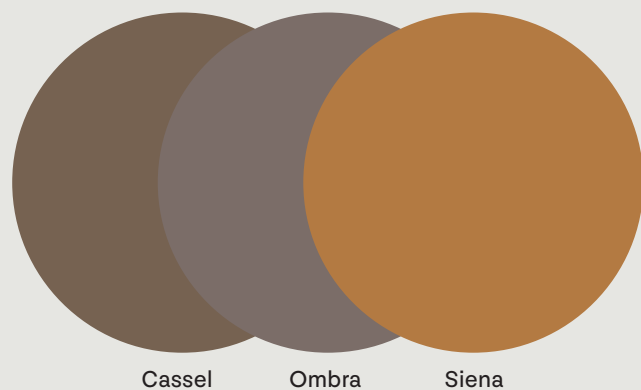

Collezione composta da tavolini in polimero ad alta densità e finitura in argilla. Trattamento antimacchia opaco. Disponibile in quattro dimensioni e tre colori.

The collection is made up of side tables made of high-density polymer and finished with a clay layer. Matt stain-proof treatment. Available in four sizes and three colours.

La collection se compose de tables basses en polymère haute densité, finition avec couche d'argile. Traitement antitache mat. Disponible en quatre tailles et trois couleurs.

Die Kollektion besteht aus Couchtischen aus Polymer höher Dichte, Endsicht aus Ton. Matte Oberflächenbehandlung gegen Flecken. Erhältlich in vier verschiedenen Größen und drei Farben.



Guna 11, 12

(→)





Guna 11

p. 016, 074, 154, 158, 161

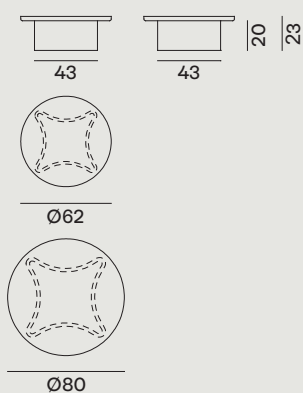

Guna 12

p. 016, 028, 079, 158, 161

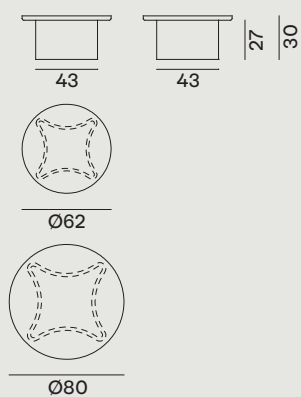

Millgres

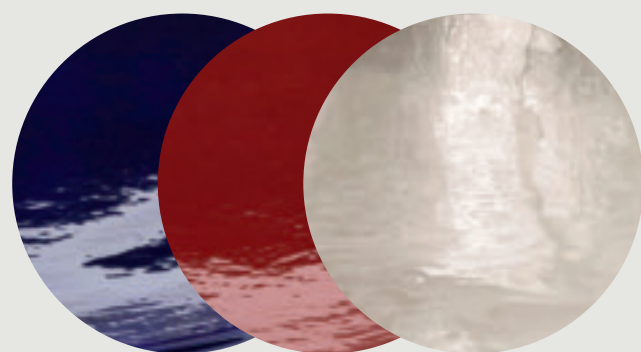

Blue

Red

White

La resistenza agli agenti atmosferici e all'umidità rende il Millgres un materiale perfetto per il mondo outdoor. Inoltre, la facilità di manutenzione per le qualità antimacchia e di lavaggio con detersivi comuni, lo rendono idoneo anche al contatto con gli alimenti.

Grâce à sa résistance aux agents atmosphériques et à l'humidité, le Millgres est un matériau parfait pour la vie à l'extérieur. Grâce à sa facilité d'entretien, à ses qualités antitaches et de nettoyage avec un détergent ordinaire, il est adapté au contact avec les aliments.

The resistance to weather agents and to humidity makes Millgres a perfect material for the outdoor world. Furthermore, the easy maintenance thanks to its stain-proof qualities and ability to be washed with common detergents make it also suitable to be used for foods.

Die Witterungs- und Feuchtigkeitsbeständigkeit macht Millgres zu einem perfekten Material für die Outdoor-Welt. Außerdem machen es die einfache Instandhaltung dank seiner fleckenabweisenden Eigenschaften und die einfache Reinigung mit herkömmlichen Putzmitteln auch für den Kontakt mit Lebensmitteln geeignet.

Brise 43, 44, 46

(→)





Brise 43
p. 019, 022, 070, 081, 095

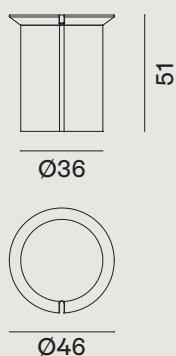

Brise 44
p. 019, 071, 080, 095, 188

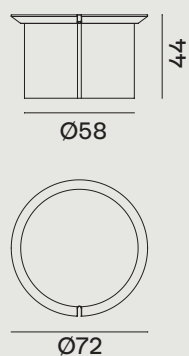

Brise 46
p. 020, 080-081, 095

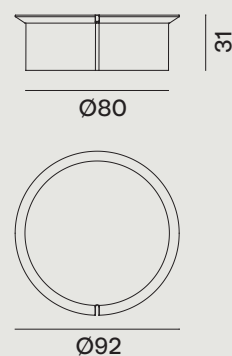

Millgres

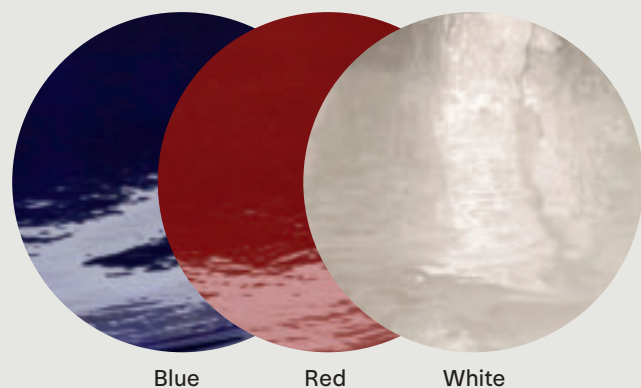

La resistenza agli agenti atmosferici e all'umidità rende il Millgres un materiale perfetto per il mondo outdoor. Inoltre, la facilità di manutenzione per le qualità antimacchia e di lavaggio con detergenti comuni, lo rendono idoneo anche al contatto con gli alimenti.

Grâce à sa résistance aux agents atmosphériques et à l'humidité, le Millgres est un matériau parfait pour la vie à l'extérieur. Grâce à sa facilité d'entretien, à ses qualités antitaches et de nettoyage avec un détergent ordinaire, il est adapté au contact avec les aliments.

The resistance to weather agents and to humidity makes Millgres a perfect material for the outdoor world. Furthermore, the easy maintenance thanks to its stain-proof qualities and ability to be washed with common detergents make it also suitable to be used for foods.

Die Witterungs- und Feuchtigkeitsbeständigkeit macht Millgres zu einem perfekten Material für die Outdoor-Welt. Außerdem machen es die einfache Instandhaltung dank seiner fleckenabweisenden Eigenschaften und die einfache Reinigung mit herkömmlichen Putzmitteln auch für den Kontakt mit Lebensmitteln geeignet.

Brise 53, 54, 56

(→)



Brise 53, 54, 56



Brise 53
p. 011, 066, 071, 094

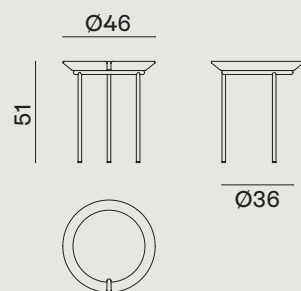

Brise 54
p. 021, 022, 066, 070

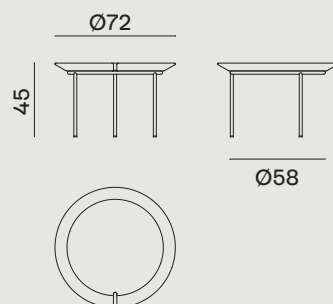

Brise 56
p. 070, 073, 094

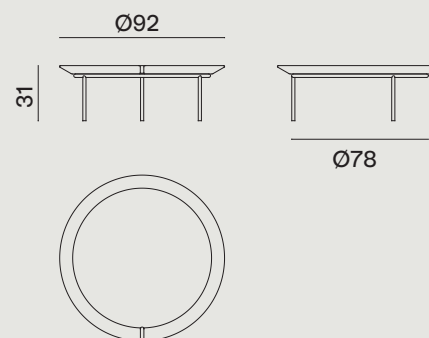

Millgres

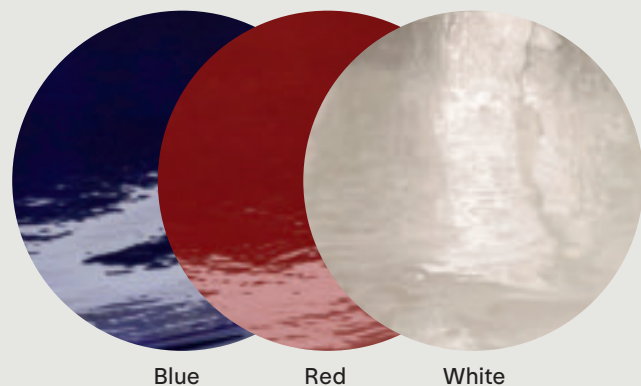

La resistenza agli agenti atmosferici e all'umidità rende il Millgres un materiale perfetto per il mondo outdoor. Inoltre, la facilità di manutenzione per le qualità antimacchia e di lavaggio con detergenti comuni, lo rendono idoneo anche al contatto con gli alimenti.

The resistance to weather agents and to humidity makes Millgres a perfect material for the outdoor world. Furthermore, the easy maintenance thanks to its stain-proof qualities and ability to be washed with common detergents make it also suitable to be used for foods.

Grâce à sa résistance aux agents atmosphériques et à l'humidité, le Millgres est un matériau parfait pour la vie à l'extérieur. Grâce à sa facilité d'entretien, à ses qualités antitaches et de nettoyage avec un détergent ordinaire, il est adapté au contact avec les aliments.

Die Witterungs- und Feuchtigkeitsbeständigkeit macht Millgres zu einem perfekten Material für die Outdoor-Welt. Außerdem machen es die einfache Instandhaltung dank seiner fleckenabweisenden Eigenschaften und die einfache Reinigung mit herkömmlichen Putzmitteln auch für den Kontakt mit Lebensmitteln geeignet.

Stainless Steel

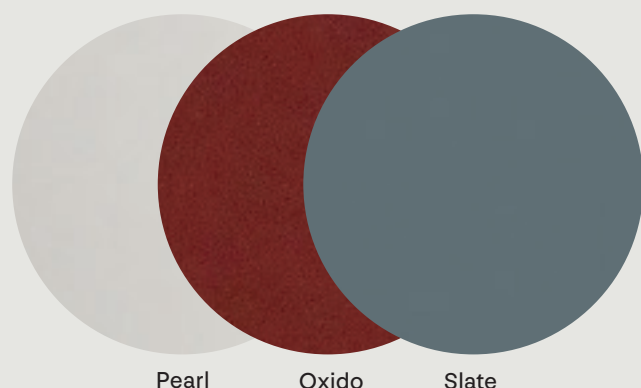

Caratterizzato da stabilità e forza, resistenza alla ruggine e a una maggiore resistenza all'ossidazione e alla corrosione, l'acciaio inox trattato per esterni è ampiamente utilizzato negli arredi outdoor. Il trattamento finale migliora la stabilità agli agenti atmosferici e all'inquinamento.

Characterised by stability and strength, resistance to rust and a greater resistance to oxidation and corrosion, the stainless steel treated for outdoors is widely used in outdoor furnishings. The final treatment improves the stability to weather agents and to pollution.

Caractérisé par stabilité et force, résistance à la rouille et une résistance accrue à l'oxydation et à la corrosion, l'acier inoxydable traité pour l'extérieur est largement utilisé pour le mobilier d'extérieur. Le traitement final améliore la stabilité aux agents atmosphériques et à la pollution.

Geprägt durch Stabilität und Kraft, Rostbeständigkeit und hohe Beständigkeit gegenüber Oxidation und Korrosion, wird der für Außenbereiche behandelte Edelstahl häufig in Outdoor-Umgebungen eingesetzt. Die Endbehandlung verbessert die Witterungs- und Schmutzbeständigkeit.

Jeko 11, 14





Jeko 11, 14, 40, 41, 46

Jeko 11, 14



Jeko 11
p. 038-039, 040, 046

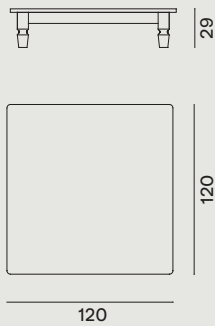

Jeko 14
p. 037

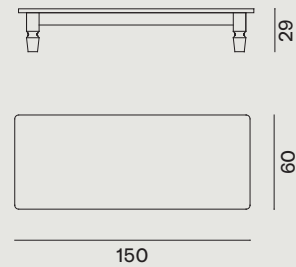

Jeko 40, 41, 46



Jeko 40
p. 033, 034, 036, 191

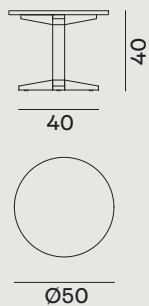

Jeko 41
p. 033, 036, 191

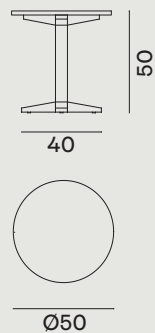

Jeko 46
p. 036, 191

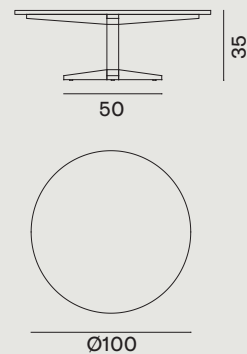

ECOTEAK



L'ECOTEAK utilizzato per la collezione proviene dal riutilizzo di travi ed elementi in teak recuperati dalla demolizione delle tradizionali case in legno dell'isola di Giava, Indonesia. La finitura finale prevede la lucidatura a mano con panni di canapa e trucioli.

L'ECOTEAK utilisé dans cette collection provient de poutres et d'éléments en teck récupérés lors de la démolition des maisons traditionnelles en bois de l'île indonésienne de Java. L'étape finale prévoit un cirage à la main à l'aide de tissus en chanvre et de copeaux.

The ECOTEAK used in the collection is obtained from old teak beams and elements recovered from the demolition of traditional wooden homes on the Island of Java, in Indonesia. The final finish is obtained by hand polishing with hemp cloths and shavings.

Das ECO Teak, das für die Kollektion eingesetzt wird, geht auf wiederverwendete Balken und Elemente aus Teakholz zurück, die aus den abgerissenen traditionellen Holzhäusern der indonesischen Insel Java gewonnen werden. Das abschließende Finish basiert auf einer von Hand ausgeführten Politur mit Hanftüchern und Spänen.

White Carrara Marble



Alle qualità estetiche, il marmo abbina caratteristiche strutturali, fisiche e morfologiche che lo rendono naturalmente compatto, resistente all'usura e idoneo al contatto con gli alimenti. Il marmo utilizzato in collezione è trattato con impregnante protettivo trasparente opaco.

Le marbre allie à ses qualités esthétiques des propriétés structurelles, physiques et morphologiques qui le rendent naturellement solide, résistant à l'usage et adapté au contact avec les aliments. Le marbre utilisé dans cette collection est protégé à l'aide d'un imprégnant transparent opaque.

The aesthetic qualities of marble are combined with structural, physical and morphological characteristics making it naturally compact, resistant to wear and suitable for contact with food. The marble used in the collection is treated with a clear matt protective impregnating agent.

Neben seinen ästhetischen Qualitäten verbindet der Marmor strukturelle, physische und morphologische Eigenschaften, dank derer er von Natur aus kompakt, widerstandsfähig und für den Kontakt mit Lebensmitteln geeignet ist. Der für die Kollektion verwendete Marmor wird mit einer matt-transparenten Schutzschicht imprägniert.

Inout 742, 744

(→)



Inout 742, 744



Inout 742 p. 176, 177, 178

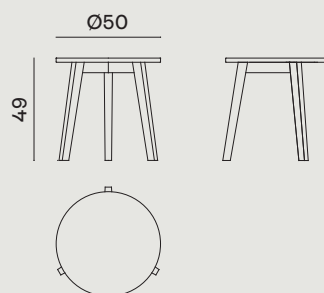

Inout 744 p. 176, 177, 178

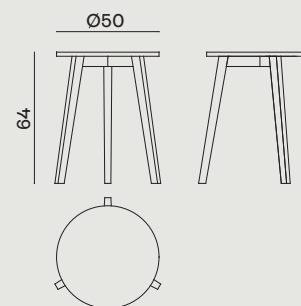

Iroko



Il legno Iroko è una specie particolarmente dura proveniente dalle foreste dei paesi dell'Africa equatoriale. Essendo un legno resinoso è per natura protetto dall'acqua e dall'umidità. Ha notevoli qualità meccaniche, come la particolare resistenza alla flessione. L'Iroko utilizzato nella collezione è legno massello stabilizzato in forni di essiccazione e successivamente oliato, procedimenti che, oltre ad aumentarne la compattezza, ne esaltano anche le venature o sfumature di colore.

L'iroko est une espèce particulièrement dure provenant des forêts d'Afrique équatoriale. En tant que résineux, il est naturellement protégé de l'eau et de l'humidité. Il possède de remarquables propriétés mécaniques, comme sa résistance particulière à la flexion. L'iroko utilisé dans cette collection est un bois massif séché au four et après huilé, ce qui non seulement augmente sa compacité, mais exalte également ses veines ou ses nuances de couleur.

Iroko wood is a particularly hard species from the forests of tropical Africa. Being a resinous wood, it is naturally protected against water and moisture. It features impressive mechanical qualities, such as resistance to bending. The Iroko used in the collection is a solid wood stabilised in drying ovens and oiled afterwards, procedures which not only improve its compactness but also highlights grains and shades of colour.

Iroko ist ein besonders hartes Holz aus den Wäldern Äquatorialafrikas. Da es sich um ein harzreiches Holz handelt ist es von Natur aus wasser- und feuchtigkeitsfest. Es besitzt außergewöhnliche mechanische Eigenschaften, darunter die besondere Festigkeit. Bei dem für diese Kollektion verwendete Iroko, handelt es sich um ein Massivholz, das in Trockenöfen stabilisiert und danach geölt wird, was ihm nicht nur mehr Dichte verleiht, sondern auch seine Maserung und die Farbnuancen hervorhebt.

White Carrara Marble



Alle qualità estetiche, il marmo abbina caratteristiche strutturali, fisiche e morfologiche che lo rendono naturalmente compatto, resistente all'usura e idoneo al contatto con gli alimenti. Il marmo utilizzato in collezione è trattato con impregnante protettivo trasparente opaco.

Le marbre allie à ses qualités esthétiques des propriétés structurelles, physiques et morphologiques qui le rendent naturellement solide, résistant à l'usure et adapté au contact avec les aliments. Le marbre utilisé dans cette collection est protégé à l'aide d'un imprégnant transparent opaque.

The aesthetic qualities of marble are combined with structural, physical and morphological characteristics making it naturally compact, resistant to wear and suitable for contact with food. The marble used in the collection is treated with a clear matt protective impregnating agent.

Neben seinen ästhetischen Qualitäten verbindet der Marmor strukturelle, physische und morphologische Eigenschaften, dank derer er von Natur aus kompakt, widerstandsfähig und für den Kontakt mit Lebensmitteln geeignet ist. Der für die Kollektion verwendete Marmor wird mit einer matt-transparenten Schutzschicht imprägniert.



Panda 11, 13



Panda 11 p. 206-207, 211

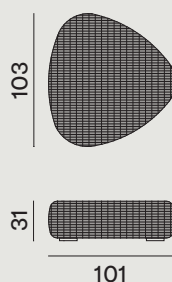

Panda 13 p. 202, 206, 208

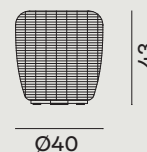

Panda Resin

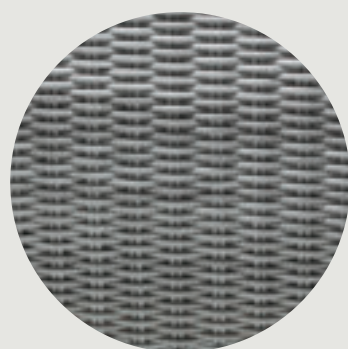

L'intreccio della collezione è realizzato con una fettuccia estrusa (Panda resin) in polietilene. Appositamente progettata per l'outdoor, è una fibra dall'aspetto naturale, forte, flessibile e durevole, conforme agli standard più severi in termini di resistenza alle radiazioni solari, all'umidità e all'acqua (anche acqua di mare e acqua clorata). Panda resin è realizzata con polietilene di alta qualità e coloranti inorganici ed ecologici, in conformità alla normativa internazionale REACH in tema di gestione dei rischi delle sostanze chimiche. La qualità ecologica del materiale e dei processi produttivi è convalidata dalla certificazione STANDARD 100 by OEKO-TEX®. Panda resin è 100% riciclabile.

Le tressage de cette collection est réalisé à l'aide d'un ruban extrudé (Panda resin) en fibre synthétique. Spécifiquement conçue pour l'extérieur, il s'agit d'une fibre d'aspect naturel, solide, flexible et durable, conforme aux standards les plus exigeants en termes de résistance aux rayonnements solaires, à l'humidité et à l'eau (y compris à l'eau de mer et à l'eau chlorée). Cette fibre est réalisée à base de polyéthylène haute qualité et de colorants inorganiques et écologiques, conformément à la réglementation internationale REACH en matière de gestion des risques liés aux substances chimiques. La qualité écologique des produits et des procédés de fabrication est garantie par la certification STANDARD 100 by OEKO-TEX®. Elle est 100 % recyclable.

The weave used in the collection is developed with extruded polyethylene fiber (Panda resin). Specifically designed for outdoor furniture, the fibre is characterised by its natural appearance, strength, flexibility and durability and satisfies the strictest standards in terms of resistance to solar radiation, moisture and water (including sea water and chlorinated water). Panda resin is made with high quality polyethylene and inorganic, ecological dyes in compliance with the international REACH standard concerning the management of risks linked to chemical substances. The ecological quality of the material and the manufacturing processes is validated by OEKO-TEX® STANDARD 100 certification. Panda resin is 100% recyclable.

Das Flechtwerk der Kollektion wird aus extrudierten Bändern (Panda resin) aus Polyethylen hergestellt, das speziell für den Outdoor-Gebrauch entwickelt wurde. Es handelt sich um eine natürlich wirkende, starke, flexible und langlebige Faser, die den strengsten Standards hinsichtlich der Widerstandsfähigkeit gegenüber Sonnenstrahlen, Feuchtigkeit und Wasser (einschließlich Meerwasser und gechlortem Wasser) entspricht. Panda resin wird aus Polyethylen bester Qualität mit anorganischen, ökologischen Farbstoffen hergestellt, gemäß der internationalen REACH-Norm zum Umgang mit chemischen Stoffen. Die umweltfreundliche Qualität der Produkte und der Produktionsprozesse wird durch die Zertifizierung STANDARD 100 by OEKO-TEX® garantiert. Panda resin ist 100 % recycelbar.

Guna Rugs





Rug Guna Blu

p. 037, 080, 092, 158, 162, 167, 188, 206

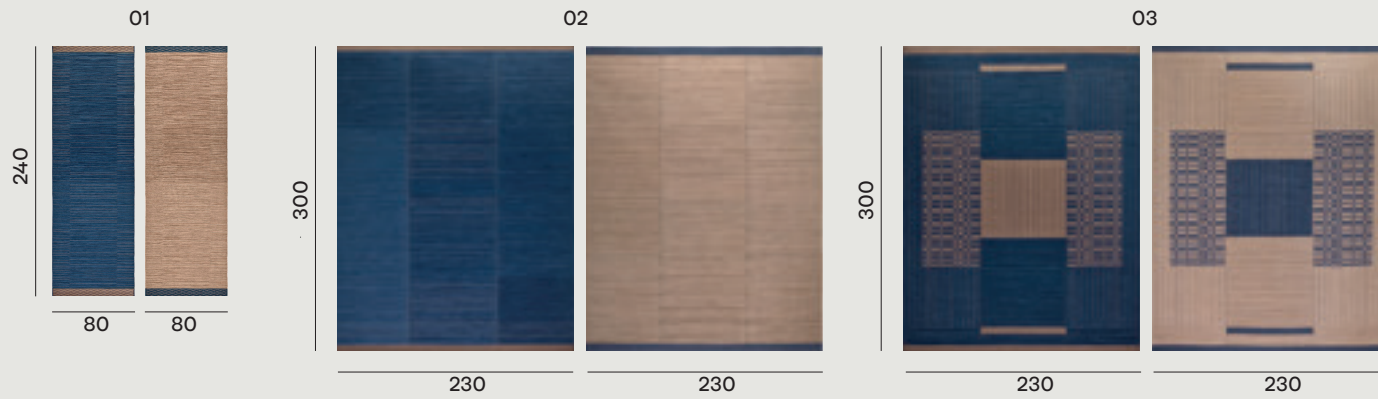

Rug Guna Red

p. 037, 080, 092, 158, 162, 167, 188, 206

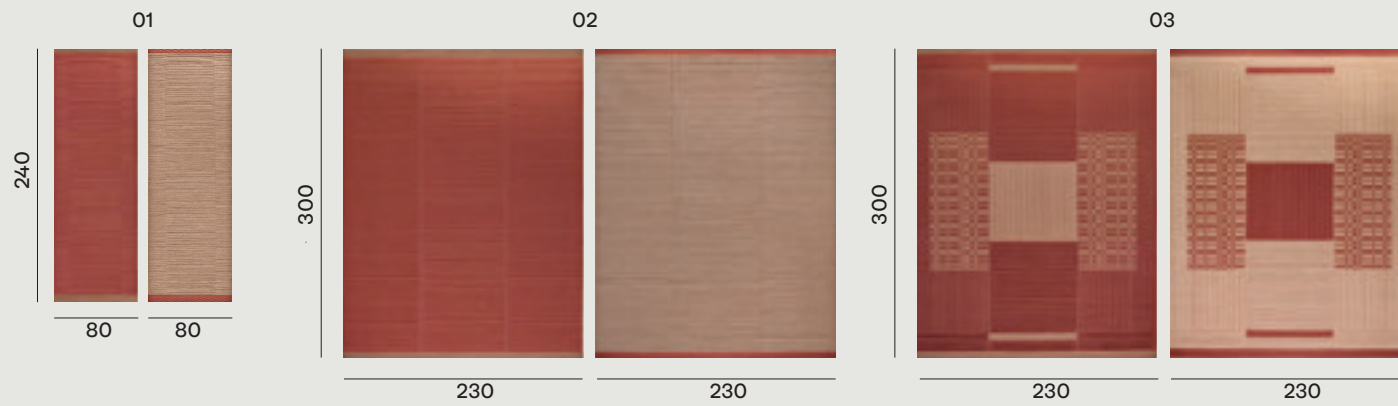

Rug Guna Natural

p. 037, 080, 092, 158, 162, 167, 188, 206

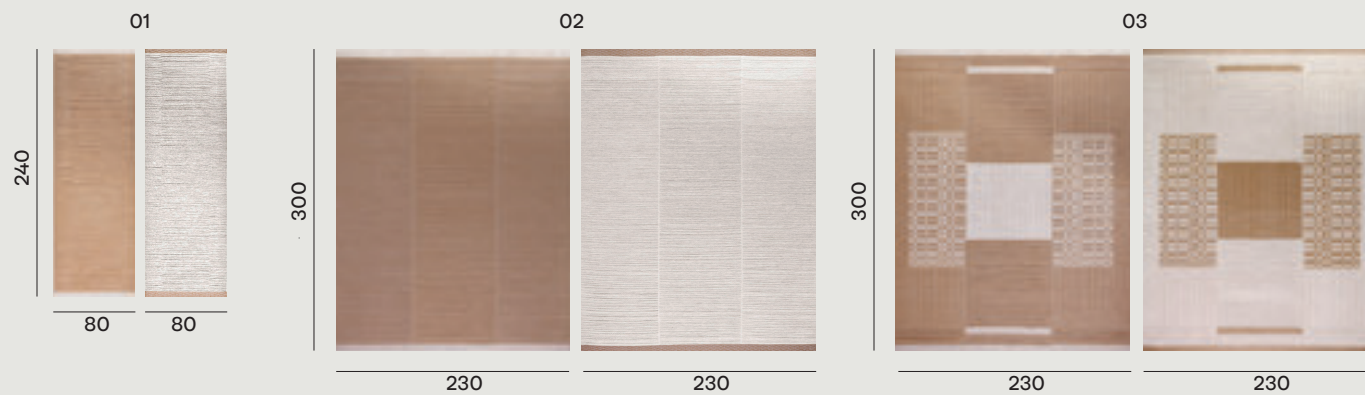

Polypropylene yarn



Il tappeto Guna è realizzato con la raffinata tecnica della maglieria artigianale, trasportata nella perfezione e serialità dei telai industriali. Un sottilissimo filato in polipropilene, in due colori a contrasto, viene intrecciato per dare vita ad un tappeto disponibile in due versioni, una con texture rigata monocroma in due dimensioni (80x240 e 230x300 cm) e una più decorativa nella misura 230x300. Guna è proposto in tre varianti colore, Blue, Red e Natural, ed è adatto sia per ambienti indoor sia outdoor. Tutte le versioni sono double face.

Le tapis Guna est réalisé avec la technique raffinée du tricotage artisanal, appliquée à la perfection et à la sérialité des métiers à tisser industriels. Un fil de polypropylène ultra fin et de deux couleurs contrastées est tissé pour créer un tapis, disponible en deux versions : une avec une texture rayée monochrome en deux dimensions (80x240 et 230x300 cm) et l'autre plus décorative en 230x300cm. Guna est proposé en trois variantes de couleurs : Blue, Red et Natural. Il peut aussi être utilisé à la fois à l'intérieur et à l'extérieur. Toutes les versions sont double face.

The Rug Guna is made with the refined artisan knitwear technique, transported into the perfection and seriality of industrial looms. A very fine polypropylene yarn, in two contrasting colours, is woven to create a rug available in two versions, one with a monochrome, striped texture in two sizes (80x240 and 230x300 cm) and a more decorative version in the 230x300 cm size. Guna is available in three colour options, Blue, Red and Natural, and it is suitable for both indoors and outdoors. All versions are reversible.

Der Teppich Guna wird mit der raffinierten handwerklichen Stricktechnik, die auf die Perfektion und Serienherstellung der industriellen Rahmen übertragen wurde, hergestellt. Ein hauchdünnes Garn aus Polypropylen in zwei kontrastierenden Farben wird verflochten, um einen Teppich in zwei Variationen entstehen zu lassen, einer einfarbigen Version mit gestreifter Textur in zwei Größen (80 x 240 und 230 x 300 cm) und einer dekorativeren Version mit den Abmessungen 230 x 300. Guna wird in drei Farbvarianten - Blue, Red und Natural - angeboten und eignet sich sowohl für den Indoor- als auch für den Outdoor-Einsatz. Alle Versionen sind wendbar.

Eco Rugs

(→)



Rug Eco Green

p. 012-013, 021, 022, 033, 171, 172, 191

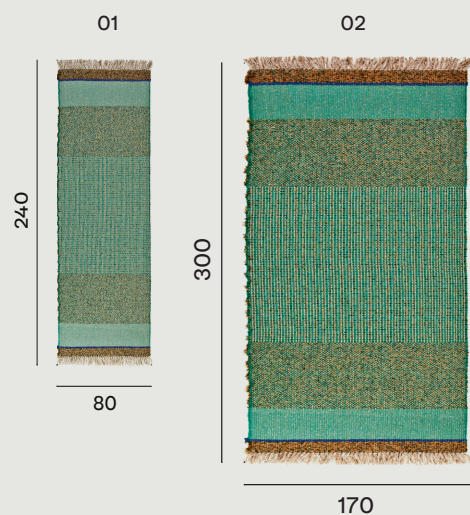

Rug Eco Natural

p. 012-013, 021, 022, 033, 171, 172, 191

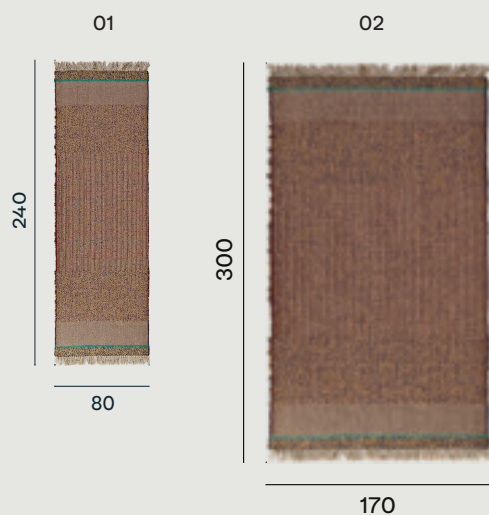

Rug Eco White

p. 012-013, 021, 022, 033, 171, 172, 191

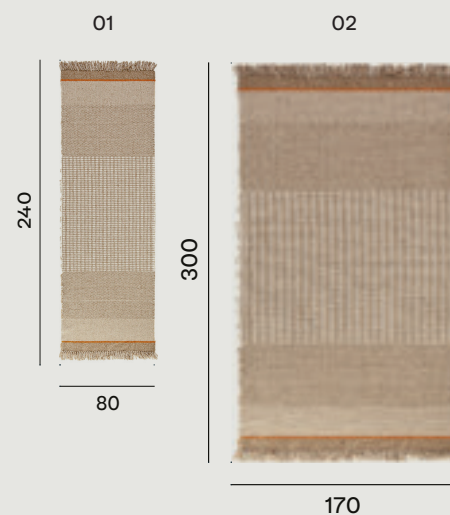

Polypropylene yarn



Una trama di filati, colori e punti diversi, dà vita a tre varianti "Green contrast", "White contrast" e "Natural contrast". La sintesi tra tradizione e innovazione emerge anche nella scelta dei materiali utilizzati, iuta e propilene, entrambi idonei per l'utilizzo in esterno e resistenti all'acqua.

Une trame de fils, de couleurs et de points différents, crée trois variantes: "Green contrast", "White contrast" et "Natural contrast". La synthèse entre tradition et innovation émerge également dans le choix des matériaux utilisés, jute et propylène, tous les deux adaptés à un usage extérieur et résistants à l'eau.

A weave of yarns, colours and various stitches, gives life to three variations: "Green contrast", "White contrast" and "Natural contrast". The fusion of tradition and innovation is also evident in the choice of the materials used, namely jute and propylene, which are both suitable for outdoor use and water-resistant.

Eine Struktur aus unterschiedlichen Garnen, Farben und Knoten lässt drei Varianten "Green contrast", "White contrast" und "Natural contrast" entstehen. Die Synthese zwischen Tradition und Innovation zeigt sich auch in der Materialauswahl, Jute und Polypropylen, beide wasserfest und damit für Outdoor-Anwendungen geeignet.







Polyethylene weaving



L'intreccio in polietilene ad alta densità lavorato a maglie irregolari diventa il paralume di una lampada a sospensione per esterno. Random 96 coniuga la poesia di un paralume di pizzo con la resistenza all'acqua e all'umidità.

A mesh in high-density polyethylene rope with an irregular grid becomes the lampshade of an outdoor suspension lamp. Random 96 has the poetry of a lace lampshade, but is perfectly resistant to water and moisture.

Un maillage irrégulier réalisé en corde de polyéthylène haute densité sert d'abat-jour à cette suspension d'extérieur. Elle a la poésie d'un abat-jour en dentelle, mais résiste parfaitement à l'eau et à l'humidité.

Ein aus Seil aus Polyethylen hoher Dichte geschaffenes Netz wird zum Schirm für eine Hängelampe für den Außenbereich. Random 96 besitzt die Poesie von Spitze, ist aber vollkommen wasser- und feuchtigkeitsbeständig.



Tessuti. I rivestimenti tessili in catalogo – più di 70 tessuti in tinta unita o decorati, in polipropilene, poliestere o canapa – sono sviluppati e confezionati per essere forti, idrorepellenti, antimuffa e resistere nel tempo alle condizioni esterne. Come l'interno della casa, anche l'outdoor può vestirsi di colore e trasformarsi facilmente, assecondando i gusti e le stagioni, semplicemente cambiando il tessuto del rivestimento.

Tissus. Les revêtements textiles du catalogue - plus de 70 tissus en teinte unie ou décorés, en polypropylène, polyester ou chanvre - sont conçus pour être forts, hydrofuges, anti-moisissures et pour résister dans le temps aux conditions extérieures. Comme l'intérieur de la maison, l'extérieur peut s'habiller de couleur et se transformer facilement, suivant nos goûts et au rythme des saisons, en changeant tout simplement le tissu du revêtement.

Fabrics. The fabric coverings present in the catalogue – more than 70 fabrics, solid colour or decorated, in polyester or hemp – were developed and produced to be strong, water-resistant, mould-proof and resistant to weather conditions over time. Like the inside of the home, the outdoors too can cover itself in colour and be easily transformed, pandering to taste and seasons, simply by changing the fabric of a covering.

Stoffe. Die textilen Bezüge im Katalog – mehr als 70 einfarbige oder gemusterte Stoffe, aus Polypropylen, Polyester oder Hanf – wurden entwickelt und genäht, um stark, wasserabweisend, schimmelabweisend und langfristig witterungsbeständig zu sein. Wie das Hausinnere kann sich auch der Outdoor-Bereich in Farben kleiden und je nach Geschmack und Jahreszeit durch simples Ändern des Bezugs verändern.

Protection cover



Fodera protettiva. Per ogni prodotto Gervasoni outdoor è possibile richiedere la fodera protettiva in poliestere. Si raccomanda, prima di procedere alla loro copertura, di verificare che gli elementi siano perfettamente asciutti onde evitare l'accumulo di umidità o la formazione di macchie di muffa.

Housse de protection. Pour tous les produits pour l'extérieur Gervasoni vous pouvez demander la housse de protection en tissu polyester. Avant de recouvrir les articles, il est donc conseillé de les faire sécher complètement pour éviter l'accumulation d'humidité et la formation de moisissure.

Protective cover. For every Gervasoni outdoor product, it is possible to request a protective cover in polyester. Make sure, before covering the products, that they are perfectly dry in order to avoid moisture stagnation and mold built-up.

Schutzhussen. Für jedes Outdoor-Produkt von Gervasoni kann eine Schutzhusse aus Polyester-Stoff angefordert werden. Vor Überziehen der Schutzhussen die Sitzelemente unbedingt trocknen lassen, um Feuchtigkeit und Schimmelbildung zu vermeiden.



Abacus

Index by
Categories

Armchairs

Ghost Out 05
p. 191



Ghost Out 09
p. 192, 194-195



Hashi 09
p. 018-019, 020, 021, 070-071,
188-189



Inout 701
p. 172-173, 176-177



Inout 707
p. 174, 175, 179



Inout 709
p. 171, 172-173, 178



Inout 809
p. 124, 125



Inout 825
p. 134, 135



Inout 851
p. 120, 121



Inout 856
p. 102, 105, 122-123



Jeko 05
p. 038-039, 041



Jeko 26
p. 028, 037



Panda 05
p. 205, 206-207, 210



Panda 19
p. 209, 212, 213



Sofa

Flair Configurations

p. 070-071, 073, 074-075, 076-077, 079, 080-081

Ghost Out 10, 12

p. 190-191, 194-195



Ghost Out 16

p. 187, 188-189

Hashi Configurations

p. 012-013, 014, 015, 016-017, 018-019, 022



Inout 703

p. 172-173, 177

Inout 852, 853

p. 122-123



Jeko 01

p. 046-047

Jeko 04

p. 038-039, 040, 041, 046-047



Jeko 07
p. 042-043, 044



Panda 01
p. 209, 211



Panda 02, 03
p. 211



Panda 04
p. 206-207, 208



Day-bed

Guna 01
p. 157, 158-159, 160



Guna 02
p. 157, 158-159, 160



Inout 81
p. 142, 143

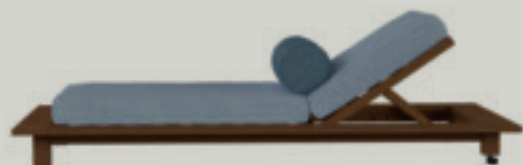

Inout 858, 859 L-R
p. 130-131, 132, 133



Inout 883
p. 112-113, 115, 116-117, 153



Inout 884
p. 116-117, 153



Jeko 81
p. 033, 034



Tables

Brise 33, 34
p. 092, 096, 097

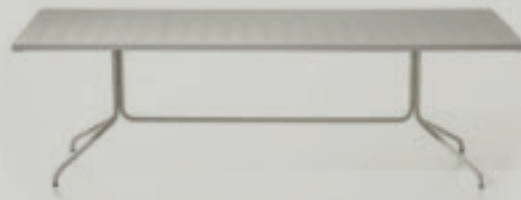

Brise 38
p. 089, 093



Inout 33, 34
p. 106-107, 108, 109, 221



Inout 35
p. 114



Inout 137
p. 111, 224, 225



Inout 143, 144
p. 126-127, 128, 138-139, 140



Inout 834, 836
p. 110, 218, 222



Inout 837, 838
p. 194, 209, 246, 266



Inout 847, 848
p. 136, 137, 196, 197



Jeko 31
p. 032



Jeko 33, 34
p. 048-049, 051



Jeko 35
p. 031, 035



Kasane 33
p. 056, 060-061, 074-075



Kasane 35



Kasane 36
p. 059, 062-063



Coffee Tables

Brise 43
p. 012-013, 019, 022, 070-071, 081, 095



Brise 44
p. 012-013, 019, 071, 080, 095, 188



Brise 46
p. 008, 019, 020, 080-081, 095



Brise 53
p. 011, 012-013, 014, 017, 021, 066,
071, 094



Brise 54
p. 021, 022, 066, 070-071, 094



Brise 56
p. 070-071, 073, 094



Guna 11
p. 016-017, 074-075, 076-077, 079,
158-159, 161



Guna 12
p. 012-013, 016-017, 028, 037, 074-
075, 076-077, 079, 158-159, 161



Inout 155
p. 120



Inout 742, 744
p. 176, 177, 178



Jeko 11
p. 038-039, 040, 046



Jeko 14
p. 037



Jeko 40, 41
p. 033, 034, 036, 191



Jeko 46
p. 036, 191



Panda 11
p. 206-207, 211



Heiko 41, 42, 43, 44
p. 172-173, 282



Chairs

Brise 23
p. 059, 062-063, 086, 089,
090-091, 138-139, 140



Brise 24
p. 059, 062-063, 090-091,
138-139



Ghost Out 23
p. 032, 060-061, 092-093,
126-127



Ghost Out 25
p. 196, 197



Inout 823
p. 096, 097, 106-107, 110, 114,
126-127



Inout 824
p. 048-049, 097, 110-111, 136



Inout 828
p. 118, 119



Inout 855
p. 106-107, 109



Jeko 24
p. 031, 032, 035



Straw 23
p. 221, 222, 225



Straw 24
p. 218, 221, 222, 225



Pouf

Inout 41
p. 042-043, 077, 102, 112-113, 122-
123, 124, 131, 177



Inout 42
p. 042-043, 048-049, 122-123, 124,
131, 177, 189



Inout 43
p. 042-043, 122-123, 131, 177, 208,
210



Inout 44
p. 046, 143, 188-189, 205, 207, 211



Inout 47
p. 038-039, 041, 116-117, 130, 171, 172, 174, 177, 191, 205



Inout 48
p. 038 -039, 041, 116-117, 120, 130, 132, 177, 179, 194, 212



Inout 49
p. 038-039, 041, 115, 116-117, 130, 132, 135, 188-189



Panda 13
p. 202, 206, 208



Kasane 19



Flair 01
p. 069, 070, 076-077



Hashi 08



Rugs

Rug Eco 01
p. 012-013



Rug Eco 02
p. 012-013, 021, 022, 033, 171, 172, 191

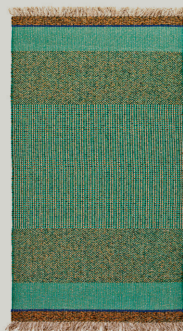

Rug Guna 01
p. 037, 080, 158-159, 162-163

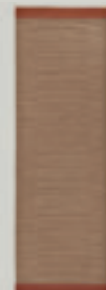

Rug Guna 02
p. 018-019, 092, 158-159, 162-163, 167, 188-189, 206-207

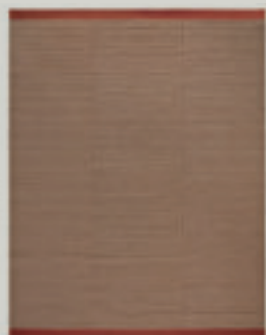

Rug Guna 03
p. 018-019, 020, 037, 158-159, 162-163, 167

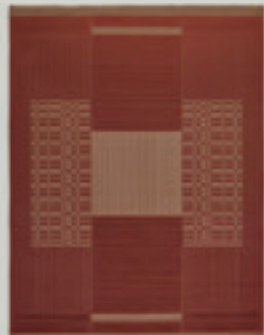

Accessories

Inout 91, 92
p. 046-047, 122-123, 135, 190, 191



Lamp

Random 96
p. 048-049, 210, 211



Credits:

Concept + Design:
Choice Studio

Product design:
Chiara Andreatti
Federica Biasi
Gabriele & Oscar Buratti
Paola Navone
Nendo
David Lopez Quincoces
Elena Sanguaneko

Photo:
Andrea Garuti Studio
Studio Eye
Beppe Brancato
Max Zambelli

Styling:
Ilaria Bacciocchi Studio
Elena Caponi
Beppe Mangia
Francesca Santambrogio

Printed in Italy:
Grafiche Antiga
September 2022

Gervasoni SpA
Viale del Lavoro, 88
33050 Pavia di Udine, Italia
T +39 0432 656611
F +39 0432 656612
info@gervasoni1882.com
www.gervasoni1882.com

Thanks to:

Alessi
alessi.com

Ames Design
amesliving.de

As'art
asart.fr

Bitossi
bitossiceramiche.it

Danese Milano
danesemilano.com

Henry Timi
henrytimi.com

Kalakera
kalakera.bigcartel.com

Riccardo Monte
riccardomonte.com

Society Limonta
societylimonta.com

Warli
warli.it

Special Thanks to:

Mondschein - Sappada
Ristorantemondschein.it

GERVASONI®

1882

Gervasoni SpA è dotata di un Sistema di Qualità Certificato UNI EN ISO 9001, di un Sistema per la gestione della Sicurezza e della Salute dei lavoratori Certificato ISO 45001 e di un Sistema di Gestione Ambientale Certificato UNI EN ISO 14001 / Gervasoni spa is certified to: UNI EN ISO 9001 Company Quality System Certification, ISO 45001 Certification for Health and Safety Management Systems and UNI EN ISO 14001 Environmental Management System Certification.



IDB

Gervasoni fa parte del gruppo Italian Design Brands /
Gervasoni is part of Italian Design Brands Group



CATOUTDOOR22B

© Copyright 2022 Gervasoni S.p.A.
Tutti i diritti riservati



The mark of
responsible forestry
FSC® C173208

